

凹型ブロック -0.1mm単位指定-



材料屋24でミスミ型番・出荷日・価格を一発表示!(http://misumi.jp/fa24)

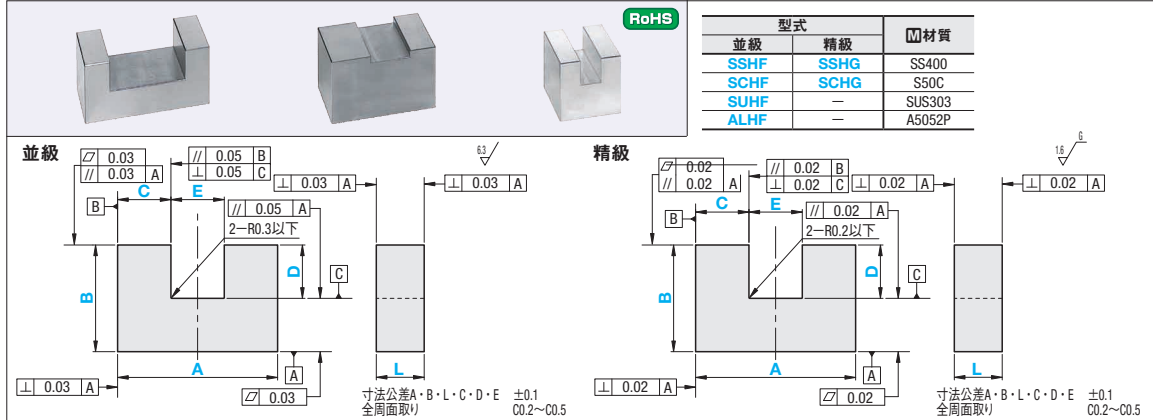

Table with columns for '並級' (Standard) and '精級' (Precision) grades, listing part numbers (SSH, SCH, SUH, ALH) and material specifications (SS400, S50C, SUS303, A5052P).

Order and price information section including 'Order 注文例' (Order Example), 'Price 価格' (Price) table, and 'Delivery 出荷日' (Delivery Date) options.

Large dimension table for concave blocks, organized by length (A) and width (B) ranges, listing prices for various materials (SS400, S50C, SUS303, A5052P).

Technical drawing and table for '精級' (Precision) concave blocks, including 'Alteration 追加加工' (Additional Processing) and 'Spec.' (Specifications) for various codes (CKA, CKB, etc.).

凸型ブロック -0.1mm単位指定-



材料屋24でミスミ型番・出荷日・価格を一発表示!(http://misumi.jp/fa24)

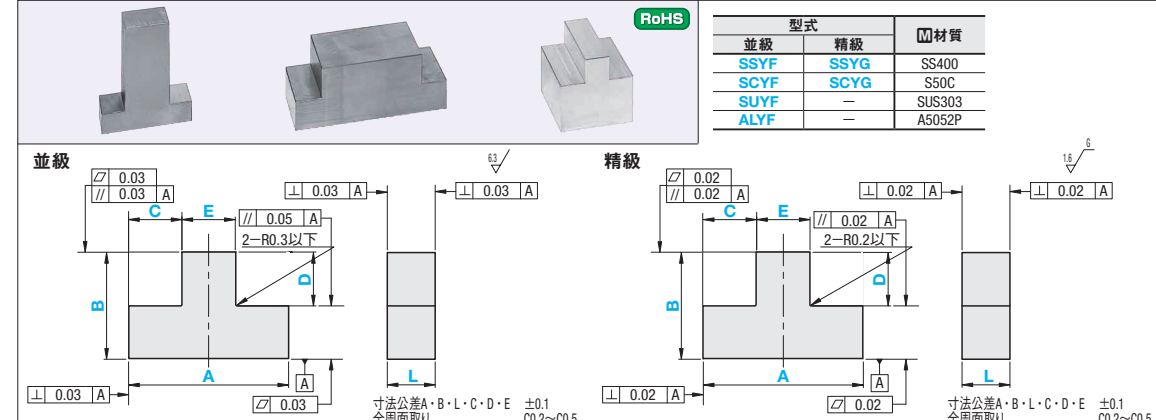

Table with columns for '並級' (Standard) and '精級' (Precision) grades, listing part numbers (SS, SC, SU, AL) and material specifications (SS400, S50C, SUS303, A5052P).

Order and price information section for convex blocks, including 'Order 注文例' (Order Example), 'Price 価格' (Price) table, and 'Delivery 出荷日' (Delivery Date) options.

Large dimension table for convex blocks, organized by length (A) and width (B) ranges, listing prices for various materials (SS400, S50C, SUS303, A5052P).

Technical drawing and table for '精級' (Precision) convex blocks, including 'Alteration 追加加工' (Additional Processing) and 'Spec.' (Specifications) for various codes (CKA, CKB, etc.).

58 金属プレート