

ANGLES / CHANELS アングル・形鋼材

最新の価格・納期・規格情報はWEBをご覧ください。

アングル
形鋼材
ANGLES
CHANELS



製品名	材料屋24 アングル・形鋼材サイト	L型アングル-素材切断Rあり2辺等辺タイプ	-素材切断Rあり不等辺タイプ
ページ	1833	1834	1834

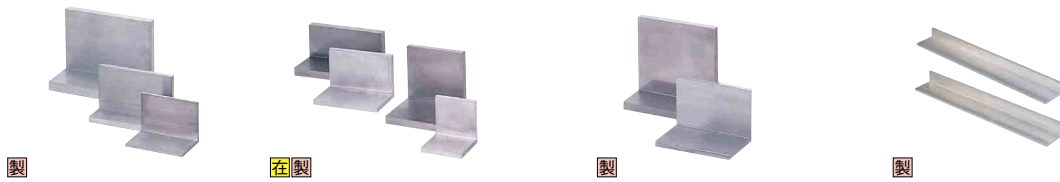

-アルミ製RなしL型アングル	-一面切削直角度外側基準3辺等辺・2辺等辺タイプ	-一面切削直角度外側基準不等辺タイプ	-角材切削直角度外側基準寸法固定タイプ
1835	1836	1837	1838



-一面切削直角度外側基準ラフフリー指定タイプ	-一面切削内側未仕上直角度外側基準フリー指定タイプ	-一面切削外側基準フリー指定タイプ	-一面切削直角度外側基準板厚フリー指定タイプ
1839	1840	1841	1844



L型表面処理アングル	L型溶接アングル	C型鋼
1845	1847	1848



金属ボックス	ボックス用ステー
1848	1848

ANGLES GUIDE L型アングル 概要

形状図	スペック			商品タイプ	掲載ページ
	外側直角度	寸法指定	材質		
<p>素材切断Rありタイプ</p>	-	2辺選択・長さフリー	SS400 A6063 SUS304	アングル素材を長さ1mm単位で指定。	P1834
<p>素材切断Rなしタイプ</p>	-	3辺フリー	A6063	アングル素材を長さ1mm単位で指定。	P1835
<p>面切削タイプ (標準)</p>	0.05 ~ 0.5	3辺フリー 3辺選択 2辺選択・長さフリー(ロング) 板厚フリー	SS400 S50C A6063 SUS304	全面を切削し外側直角度を保証した精密アングル。全辺を1mm単位指定。	P1836 ~ P1839 ・ P1841 ~ P1846
<p>面切削タイプ (内側未仕上)</p>	0.05 ~ 0.15	3辺フリー	SS400 A6063	外側のみを切削し外側直角度を保証した精密アングルのエコノミー版。全辺を1mm単位指定。	P1840
<p>溶接タイプ</p>	0.05 ~ 0.15	3辺フリー	A5052 SUS304	板を溶接接合したアングル。全辺1mm単位指定。	P1847



新価格

材料屋24でミスミ型番・出荷日・価格を一発表示!(http://misumi.jp/fa24)



『材料屋24 アングル・形鋼材サイト』

ミスミ型番・出荷日・価格を一発表示!

そのままご注文ができるWEBサイトです。

黒皮素材品から面削仕上げまでご希望のサイズで注文可能!

豊富なバリエーション! -アングル・チャンネル-

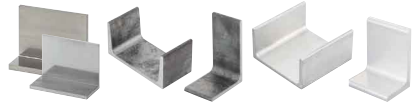

登録は無料! 今すぐお試しください。

Material House 24 search bar with URL http://misumi.jp/fa24

材料屋24 アングル・形鋼材サイト画面イメージ

Screenshot of the Material House 24 website selection interface, showing steps 1-6: 1. Shape/Material Selection, 2. Type Selection, 3. Size Input, 4. Surface Treatment, 5. Various Options, 6. Shape Options.

【選定手順】

- 1 形/材質を選ぶ: アングル・チャンネルをタブで選択可能です。
2 タイプを選ぶ: 黒皮素材切断から面削仕上げまで最大4タイプご用意。
3 サイズを入力: フリーと記載がある場合は全て1mm単位で指定可能です。

オプション(任意) 便利なオプションを多数ご用意。

- ・表面処理
・コーナーカット
・内側直角度保証
・側面直角度保証
・リップ追加(溶接のみ)
・きりかき加工
・段差加工

貴社の設備稼働状況やトータルコストからは非ご検討ください!

数量を入力して見積りボタンをクリック!

見積り結果が表示されます。選択した商品の仕様・精度をごらんで確認。問題なければ左のチェックボックスにチェックを入れて注文ボタンをクリック!

*WEB限定の定尺素材切断品をアングル219規格・チャンネル54規格取り揃えています!

Technical drawing and table for L-shaped angle with material cut R on two equal sides. Includes RoHS info, material options (LACS, LACA, LACU), and a table of dimensions and tolerances.

Main price table for L-shaped angles with material cut R on two equal sides. Columns include Type, No., L (指定1mm単位), T, T寸公差, A, r1, r2, and price ranges for various lengths (L30~49 to L250~300).

Ordering options and pricing details. Includes quantity slide pricing (R127), LACS/LACA/LACU material selection, and stock/lead time information.

Technical drawing and table for L-shaped angle with material cut R on two unequal sides. Includes RoHS info, material options (LAFS, LAFA), and a table of dimensions and tolerances.

Main price table for L-shaped angles with material cut R on two unequal sides. Columns include Type, No., L (指定1mm単位), T, T寸公差, A, B, r1, r2, and price ranges for various lengths.

Ordering options and pricing details for the second type of angle. Includes quantity slide pricing (R127), LAFS/LAFA material selection, and stock/lead time information.

59 形鋼材

アルミ製L型アングル

—素材切断Rなしフリー指定タイプ—



材料屋24でミスミ型番・出荷日・価格を一発表示! (<http://misumi.jp/fa24>)

CADデータフォルダ名: 59_Angles

アルミ製RなしL型アングル



Type	材質
LRA	A6063

●L最大長の端面形状はメタルソー切断のままです。
 ●LRA6の場合、A・B寸法のいずれかが61mm以上の時、R=6になり、LRA12の場合、いずれかが101mm以上の時、R=12となります。

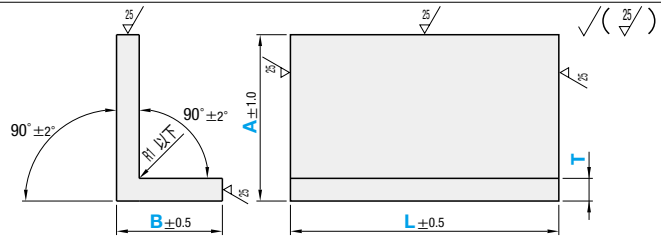

型式 Type	T	T公差	指定1mm単位		
			A	B	L
LRA	3	±0.6	20~40	20~40	20~300
	5		20~50	20~50	
	6		20~70	20~70	
	8	±0.7	20~75	20~75	
	10	±0.8	20~95	20~95	
	12	50~125	50~125		
14	50~130	50~130	51~300		
18	100~155	100~155			



Order 注文例
 型式 - A - B - L
 LRA10 - A85 - B60 - L130



Delivery 出荷日
 3 日日出荷



Price 価格
 数量スライド価格 (●1円未満切り捨て) P.127

数量区分	標準対応				個別対応
	小口	大口	小口	大口	
数量	1~9	10~19	20~49	50~80	81~
値引率	基準単価	5%	10%	10%	お見積り
出荷日	通常	通常	通常	+7日	お見積り

●表示数量超えはWOSにてご確認ください。

型式 Type	T	A	B	Y基準単価						
				L20~50	L51~100	L101~150	L151~200	L201~250	L251~300	
LRA	3	20~30	20~40	400	720	1,050	1,570	1,970	2,360	
		31~40	20~40	450	820	1,200	1,780	2,210	2,630	
		20~30	20~30	480	890	1,310	1,760	2,460	2,940	
	5	31~50	20~30	620	1,110	1,660	2,220	3,050	3,650	
		20~30	31~50	620	1,110	1,660	2,220	3,050	3,650	
		31~50	31~50	720	1,300	1,940	2,580	3,600	4,310	
	6	20~30	20~30	550	990	1,480	1,970	2,750	3,300	
		31~50	20~30	690	1,220	1,830	2,440	3,390	4,070	
		51~70	20~30	790	1,570	2,340	3,120	4,340	5,200	
		20~30	31~50	690	1,220	1,830	2,440	3,390	4,070	
		31~50	31~50	740	1,350	2,000	2,660	3,700	4,440	
		51~70	31~50	850	1,680	2,510	3,330	4,630	5,570	
8	20~30	31~50	790	1,570	2,340	3,120	4,340	5,200		
	31~50	31~50	850	1,680	2,510	3,330	4,630	5,570		
	51~70	31~50	980	1,940	2,880	3,850	5,340	6,410		
	20~30	51~70	690	1,340	2,000	2,660	3,310	3,970		
	31~50	51~70	740	1,440	2,160	2,860	3,570	4,270		
	51~75	51~70	790	1,540	2,300	3,060	3,810	4,570		
10	20~30	31~50	740	1,440	2,160	2,860	3,570	4,270		
	31~50	31~50	770	1,510	2,260	3,000	3,730	4,470		
	51~75	31~50	810	1,610	2,400	3,200	3,990	4,770		
	20~30	51~75	790	1,540	2,300	3,060	3,810	4,570		
	31~50	51~75	810	1,610	2,400	3,200	3,990	4,770		
	51~75	51~75	870	1,710	2,560	3,400	4,240	5,090		
	20~30	76~95	870	1,700	2,520	3,340	4,190	5,020		
	31~50	76~95	870	1,700	2,520	3,340	4,190	5,020		
	51~75	76~95	910	1,800	2,690	3,580	4,460	5,330		
	20~30	101~125	980	1,910	2,860	3,790	4,740	5,670		
	31~50	101~125	910	1,800	2,690	3,580	4,460	5,330		
	51~75	101~125	900	1,770	2,620	3,500	4,370	5,220		
12	76~95	101~125	960	1,880	2,790	3,710	4,650	5,570		
	20~30	101~125	1,000	1,980	2,970	3,950	4,920	5,890		
	31~50	101~125	980	1,910	2,860	3,790	4,740	5,670		
	51~75	101~125	1,000	1,980	2,970	3,950	4,920	5,890		
	20~30	126~155	1,070	2,090	3,140	4,150	5,200	6,220		
	31~50	126~155	1,000	1,980	2,970	3,950	4,920	5,890		
	51~75	126~155	1,070	2,090	3,140	4,150	5,200	6,220		
	76~95	126~155	1,160	2,270	3,410	4,520	5,660	6,770		
	50~75	140~160	—	4,440	5,260	6,070	6,900	7,700		
	76~100	140~160	—	4,860	5,800	6,710	7,660	8,560		
	101~125	140~160	—	5,360	6,530	7,690	8,860	10,010		
	50~75	176~200	—	4,860	5,800	6,710	7,660	8,560		
76~100	176~200	—	4,910	5,840	6,760	7,700	8,610			
101~125	176~200	—	5,410	6,570	7,740	8,910	10,060			
50~75	201~225	—	5,360	6,530	7,690	8,860	10,010			
76~100	201~225	—	5,410	6,570	7,740	8,910	10,060			
101~125	201~225	—	5,460	6,630	7,790	8,960	10,110			
14	50~75	226~250	—	6,760	8,540	10,330	12,160	13,930		
	76~100	226~250	—	6,990	8,790	10,570	12,400	14,170		
	101~130	226~250	—	7,210	9,000	10,790	12,610	14,390		
	50~75	251~275	—	6,990	8,790	10,570	12,400	14,170		
	76~100	251~275	—	7,130	8,910	10,700	12,530	14,300		
	101~130	251~275	—	7,260	9,040	10,840	12,670	14,440		
	50~75	276~300	—	7,210	9,000	10,790	12,610	14,390		
	76~100	276~300	—	7,260	9,040	10,840	12,670	14,440		
	101~130	276~300	—	7,310	9,100	10,890	12,710	14,490		
	100~125	301~325	—	8,780	11,100	13,430	15,760	18,090		
	126~155	301~325	—	8,880	11,200	13,530	15,860	18,190		
	150~175	301~325	—	8,880	11,200	13,530	15,860	18,190		
176~200	301~325	—	9,000	11,330	13,660	15,990	18,320			



Alteration 追加加工
 型式 - A - B - L - (CCA...etc.)
 LRA10 - A85 - B60 - L130 - CCA5・CCD5

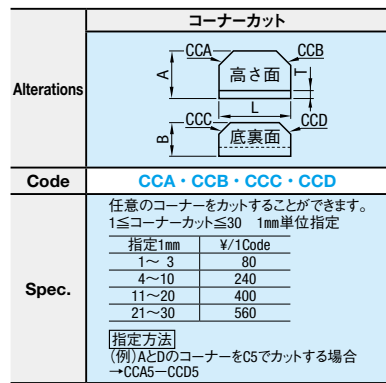

Code CCA・CCB・CCC・CCD

Spec. 任意のコーナーをカットすることができます。1≦コーナーカット≦30 1mm単位指定

指定1mm	¥/1Code
1~3	80
4~10	240
11~20	400
21~30	560

指定方法 (例)AとDのコーナーをC5でカットする場合 →CCA5-CCD5

L型アングル

—面切削直角度外側基準3辺等辺・2辺等辺タイプ—



材料屋24でミスミ型番・出荷日・価格を一発表示! (<http://misumi.jp/fa24>)

CADデータフォルダ名: 59_Angles

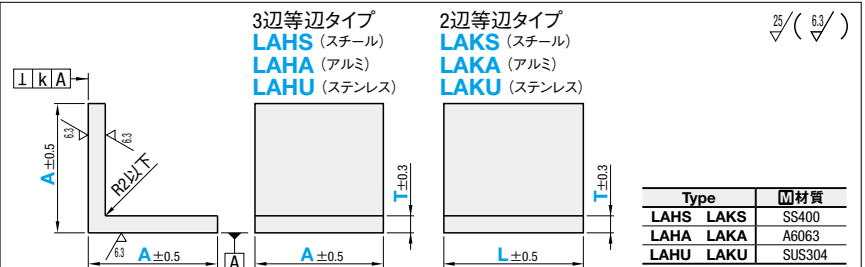

3辺等辺タイプ

型式 Type	A	T	k 直角度	LAHS		LAHA		LAHU	
				Y基準単価	Xスライド単価	Y基準単価	Xスライド単価	Y基準単価	Xスライド単価
LAHS LAHA LAHU	25	5 6	0.05	730	660	600	540	1,770	1,590
	30	5 6		840	760	710	640	1,850	1,660
	50	5 6		1,250	1,120	1,130	1,020	2,710	2,450
	75	5 6		1,570	1,410	1,380	1,250	3,030	2,720
	100	5 6		2,140	1,920	1,720	1,550	4,400	3,960
	125	5 6		2,860	2,570	2,800	2,520	4,480	4,030
LAHS LAHA LAHU	100	10	0.1	4,150	3,740	3,980	3,590	—	—
	125	10		5,470	4,920	—	—	—	—

●*はLAHUに適用されます。**はLAHS, LAHAに適用されます。

2辺等辺タイプ

型式 Type	A	L 選択	T 選択	k 直角度	LAKS		LAKA	
					Y基準単価	Xスライド単価	Y基準単価	Xスライド単価
LAKS LAKA LAKU	25	30 40 50 60 70 80 100 150	5 6	0.05	—	—	—	—
	30	—	—		—	—	—	—
	40	—	—		—	—	—	—
	50	—	—		—	—	—	—
	60	—	—		—	—	—	—
	75	—	—		—	—	—	—
LAKS LAKA LAKU	100	40 50 60 70 80 150	10	0.1	—	—	—	—
	125	—	—		—	—	—	—

●*はLAKUに適用されます。**はLAKS, LAKAに適用されます。

Price 価格

数量スライド価格 (●1円未満切り捨て) P.127

数量区分	標準対応		個別対応
	小口	大口	
数量	1~9	10~19	51~
値引率	基準単価	5%	10%
出荷日	通常	通常	お見積り

●表示数量超えはWOSにてご確認ください。

型式 Type	A	T 選択	Y基準単価																
			L30	L40	L50	LAKS			L70	L80	L100	L150	L30	L40	L50	L60	LAKA		L70
LAKS LAKA	25	5 6	960	1,130	1,320	1,510	1,690	1,870	2,280	3,280	810	990	1,150	1,310	1,480	1,670	1,980	2,780	
	30	5 6	—	1,190	1,380	1,560	1,760	1,940	2,320	3,290	—	1,050	1,200	1,360	1,550	1,740	2,100	2,950	
	40	5 6	1,050	—	1,440	1,620	1,830	2,010	2,420	3,490	970	—	1,310	1,500	1,690	1,890	2,290	3,200	
	50	5 6	1,290	—	1,770	2,010	2,260	2,490	2,990	4,240	1,260	—	1,760	1,980	2,250	2,510	3,020	4,290	
	60	5 6	1,090	1,270	—	1,670	1,860	2,040	2,440	3,500	990	1,170	—	1,510	1,720	1,910	2,320	3,210	
	75	5 6	1,320	1,560	—	2,040	2,290	2,530	3,020	4,270	1,270	1,530	—	1,990	2,250	2,520	3,060	4,320	
LAKS LAKA	60	5 6	1,330	1,570	1,810	—	2,320	2,560	3,060	4,310	1,190	1,410	1,620	—	2,050	2,270	2,700	3,810	
	75	5 6	1,790	2,150	2,510	—	3,230	3,590	4,320	6,090	1,740	2,100	2,440	—	3,150	3,510	4,230	5,990	
	100	5 6	1,380	1,610															

L型アンゲル

一面切削直角度外側基準不等辺タイプ



L型アンゲル

一角材切削直角度外側基準寸法固定タイプ



材料屋24でミスミ型番・出荷日・価格を一発表示! (<http://misumi.jp/fa24>)
CADデータフォルダ名: 59_Angles CADファイル名例: LASS→ass10051

材料屋24でミスミ型番・出荷日・価格を一発表示! (<http://misumi.jp/fa24>)
CADデータフォルダ名: 59_Angles



Type	材質
LASS	SS400
LASA	A6063
LASU	SUS304

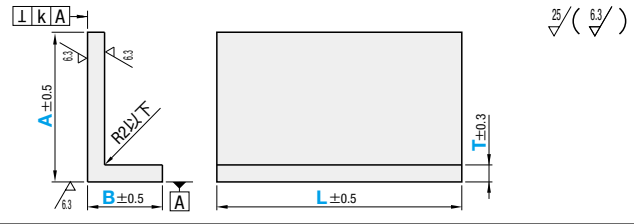

型式	Type	L 選択										T 選択		k 直角度	
		A	B	25	30	40	50	60	70	80	90	100	150		5
LASS	30	25	30	40	50	60	70	80	90	100	150	5	6	※6	※10
	40	25	30	40	50	60	70	80	90	100	150	5	6	※6	※10
	50	25	30	40	50	60	70	80	90	100	150	5	6	※6	※10
LASA	30	25	30	40	50	60	70	80	90	100	150	5	6	※6	※10
	40	25	30	40	50	60	70	80	90	100	150	5	6	※6	※10
	50	25	30	40	50	60	70	80	90	100	150	5	6	※6	※10
LASU	30	25	30	40	50	60	70	80	90	100	150	5	6	※6	※10
	40	25	30	40	50	60	70	80	90	100	150	5	6	※6	※10
	50	25	30	40	50	60	70	80	90	100	150	5	6	※6	※10
LASS	75	50	30	40	50	60	70	80	90	100	150	5	6	※6	※10
	80	40	30	40	50	60	70	80	90	100	150	5	6	※6	※10
	100	50	30	40	50	60	70	80	90	100	150	5	6	※6	※10
LASS	125	60	30	40	50	60	70	80	90	100	150	5	6	※6	※10
	150	70	30	40	50	60	70	80	90	100	150	5	6	※6	※10

型式 - L - T
LASS8040 - 70 - 6

3 日目出荷

ストーク A 翌日出荷 500円/1本 PM 6:00迄 P128

※3本以上で1明細行当たり一律1,350円

※はLASUに適用されます。*はLASS, LASAに適用されます。

数量スライド価格 (1円未満切り捨て) P127

数量区分	標準対応			個別対応
	小口	大口	大口	大口
数量	1~9	10~19	20~49	50~80
値引率	基準単価	5%	10%	10%
出荷日	通常			+7日

表示数量超えはWOSにてご確認ください。

数量スライド価格 (1円未満切り捨て) P127

数量区分	標準対応			個別対応
	小口	大口	大口	大口
数量	1~9	10~19	20~50	51~
値引率	基準単価	5%	10%	お見積り

表示数量超えはWOSにてご確認ください。

型式	Type	A	B	T 選択	¥基準単価																			
					LASS					LASA														
					L25	L30	L40	L50	L60	L70	L80	L90	L100	L150	L25	L30	L40	L50	L60	L70	L80	L90	L100	L150
LASS	30	25	30	5 6	1,050	1,140	1,360	1,580	1,830	2,060	2,290	2,540	2,770	3,840	980	1,060	1,260	1,460	1,710	1,920	2,130	2,370	2,580	3,600
				5 6	1,070	1,150	1,380	1,600	1,850	2,080	2,300	2,560	2,800	3,880	990	1,080	1,280	1,470	1,730	1,950	2,170	2,400	2,620	3,630
				10	1,230	1,330	1,580	1,830	2,100	2,350	2,620	2,900	3,170	4,400	1,200	1,290	1,530	1,790	2,060	2,300	2,560	2,860	3,100	4,350
	40	25	5 6	1,090	1,160	1,390	1,620	1,870	2,090	2,320	2,580	2,820	3,890	1,010	1,090	1,290	1,490	1,750	1,980	2,200	2,430	2,650	3,670	
			5 6	1,270	1,350	1,600	1,850	2,120	2,390	2,640	2,920	3,180	4,420	1,220	1,310	1,540	1,790	2,080	2,320	2,580	2,870	3,120	4,370	
			10	1,460	1,560	1,820	2,090	2,380	2,640	2,920	3,200	4,440	1,300	1,390	1,640	1,900	2,200	2,470	2,720	3,030	3,290	4,570		
	50	25	5 6	1,080	1,160	1,370	1,590	1,860	2,090	2,310	2,560	2,800	3,880	1,020	1,110	1,320	1,520	1,780	1,990	2,210	2,440	2,650	3,720	
			5 6	1,260	1,360	1,620	1,870	2,150	2,400	2,660	2,950	3,200	4,440	1,240	1,330	1,540	1,790	2,080	2,250	2,480	2,720	3,010	4,260	
			10	1,450	1,550	1,820	2,090	2,380	2,640	2,920	3,200	4,440	1,320	1,410	1,640	1,900	2,200	2,470	2,720	3,030	3,290	4,570		
	60	25	5 6	1,300	1,380	1,620	1,880	2,170	2,410	2,670	2,970	3,220	4,460	1,230	1,320	1,560	1,810	2,090	2,350	2,620	2,900	3,170	4,420	
			5 6	1,490	1,590	1,860	2,130	2,420	2,670	2,950	3,250	4,490	1,250	1,340	1,580	1,830	2,110	2,370	2,640	2,920	3,200	4,440		
			10	1,680	1,780	2,060	2,330	2,620	2,870	3,150	3,450	4,690	1,330	1,420	1,660	1,910	2,190	2,450	2,720	3,000	3,280	4,520		
75	30	5 6	1,330	1,430	1,700	1,950	2,250	2,500	2,770	3,070	3,350	4,630	1,300	1,380	1,640	1,890	2,200	2,470	2,720	3,030	3,290	4,570		
		5 6	1,520	1,620	1,900	2,170	2,480	2,730	3,030	3,330	4,610	1,320	1,400	1,660	1,910	2,210	2,480	2,750	3,060	3,320	4,600			
		10	1,710	1,810	2,100	2,370	2,680	2,930	3,230	3,530	4,770	1,400	1,480	1,740	2,000	2,300	2,570	2,840	3,150	3,410	4,690			
80	40	5 6	1,360	1,460	1,740	2,000	2,300	2,550	2,820	3,120	3,400	4,680	1,310	1,390	1,650	1,900	2,210	2,480	2,730	3,040	3,300	4,580		
		5 6	1,550	1,650	1,940	2,210	2,520	2,770	3,070	3,370	4,650	1,330	1,410	1,670	1,920	2,230	2,500	2,770	3,080	3,340	4,620			
		10	1,740	1,840	2,140	2,410	2,720	2,970	3,270	3,570	4,810	1,410	1,490	1,750	2,000	2,310	2,580	2,850	3,160	3,420	4,700			
100	50	5 6	1,390	1,490	1,780	2,040	2,340	2,590	2,860	3,160	3,440	4,720	1,320	1,400	1,660	1,910	2,220	2,490	2,740	3,050	3,310	4,590		
		5 6	1,580	1,680	1,980	2,250	2,560	2,810	3,110	3,410	4,690	1,340	1,420	1,680	1,930	2,240	2,510	2,780	3,090	3,350	4,630			
		10	1,770	1,870	2,170	2,440	2,750	3,000	3,300	3,600	4,840	1,420	1,500	1,760	2,010	2,320	2,590	2,860	3,170	3,430	4,710			
125	60	5 6	1,420	1,520	1,810	2,070	2,370	2,620	2,890	3,190	3,470	4,750	1,330	1,410	1,670	1,920	2,230	2,500	2,750	3,060	3,320	4,600		
		5 6	1,610	1,710	2,000	2,270	2,580	2,830	3,130	3,430	4,710	1,350	1,430	1,690	1,940	2,250	2,520	2,790	3,100	3,360	4,640			
		10	1,800	1,900	2,200	2,470	2,780	3,030	3,330	3,630	4,870	1,430	1,510	1,770	2,020	2,330	2,600	2,910	3,170	3,480	4,740			
150	70	5 6	1,450	1,550	1,840	2,100	2,400	2,650	2,920	3,220	3,500	4,780	1,340	1,420	1,680	1,930	2,240	2,510	2,760	3,070	3,330	4,610		
		5 6	1,640	1,740	2,040	2,310	2,620	2,870	3,170	3,470	4,750	1,360	1,440	1,700	1,950	2,260	2,530	2,800	3,110	3,370	4,650			
		10	1,830	1,930	2,230	2,500	2,810	3,060	3,360	3,660	4,900	1,440	1,520	1,780	2,030	2,340	2,610	2,920	3,180	3,490	4,750			

型式	Type	A	B	T 選択	¥基準単価																			
					LASS					LASA														
					L25	L30	L40	L50	L60	L70	L80	L90	L100	L150	L25	L30	L40	L50	L60	L70	L80	L90	L100	L150
LASU	30	25	30	5 6	1,800	2,140	2,600	3,070	3,540	4,010	4,500	4,980	5,180	7,410										
				5 6	1,950	2,190	2,660	3,130	3,600	4,070	4,560	5,040	5,240	7,450										
				8	2,110	2,360	2,890	3,370	3,900	4,400	4,920	5,420	5,640	8,040										
	40	25	5 6	1,950	2,200	2,670	3,150	3,610	4,100	4,580	5,070	5,250	7,470											
			5 6	2,140	2,370	2,900	3,390	3,900	4,420	4,930	5,450	5,640	8,080											
			8	2,020	2,280	2,750	3,220	3,690	4,170	4,660	5,120	5,300	7,530											
	50	25	5 6	2,190	2,460	2,950	3,490	3,980	4,500	5,010	5,530	5,720	8,140											
			5 6	2,060	2,310	2,800	3,250	3,710	4,190	4,670	5,130	5,330	7,580											
			8	2,220	2,490	2,980	3,490	4,010	4,510	5,020	5,540	5,740	8,160											
	60	25	5 6	2,080	2,310	2,800	3,260	3,720	4,220	4,690	5,140	5,360	7,590											
			5 6	2,230	2,490	2,990	3,510	4,010	4,520	5,040	5,260	7,490												
			8	2,190	2,360	2,840	3,310	3,790	4,250	4,730	4,940	5,400	7,620											
75	30	5 6	2,250	2,520	3,010	3,520	4,040	4,540	5,070	5,270	7,690													
		5 6	2,410	2,690	3,200	3,720	4,240	4,740	5,240	5,440	7,860													
		8	2,540	3,060	3,550	4,070	4,580	5,080	5,300	5,800	8,250													
80	40	5 6	2,430	2,900	3,360	3,840	4,300	4,770	4,990	5,440	7,680													
		5 6	2,550	3,070	3,590	4,080	4,600	5,090	5,320	5,800	8,250													
		8	2,710	3,250	3,790	4,330	4,880	5,420	5,650	6,160	8,740													
100	50	5 6	2,850	3,370	3,920	4,450	4,980	5,510	5,740	6,250	8,780													
		5 6	3,000	3,540	4,090	4,640	5,190	5,420	5,930	6,440	9,020													
		8	3,160	3,710	4,260	4,810	5,360	5,590	6,100	6,610	9,260													

Corner Cut 側面直角度保証

Code: CCA・CCB・CCC・CCD CKC

Spec: 任意のコーナーをカットすることができます。1≦コーナーカット≦30 1mm単位指定

指定方法 (例) AとDのコーナーをC5でカットする場合→CCA5-CCD5

指定方法 CKC

¥1Code: 800



Type	材質
LAJS	SS400
LAJC	S50C

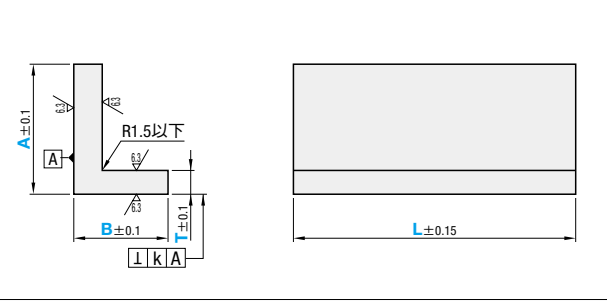

L型アンゲル

一面切削直角度外側基準ラフフリー指定タイプ



材料屋24でミスミ型番・出荷日・価格を一発表示! (<http://misumi.jp/fa24>)

CADデータフォルダ名: 59_Angles



Type	材質
LASR	SS400
LAAR	A6063
LAUR	SUS304

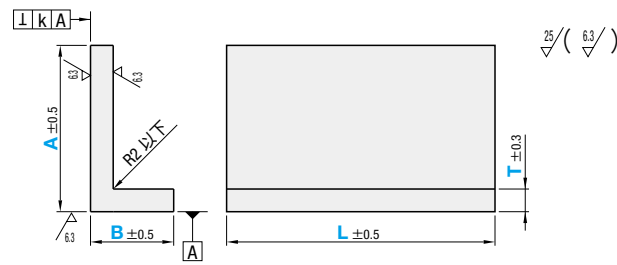

T寸法	A・B寸法の長手	直角度k
5・6	20~75	0.2
8	50~75	0.35
10	25~75	0.2
	76~100	0.3
	101~125	0.35

型式 Type	T	A	B	L	¥基準単価					
					最短L~50	L51~100	L101~150	L151~200	L201~250	L251~300
LASR (SS400)	5	25~50	25~50	25~300	1,150	2,070	3,070	3,990	4,970	5,890
		51~75			1,490	2,650	3,620	4,640	6,020	7,100
	10	25~50	1,550		2,710	3,880	5,030	6,190	7,360	
		51~75	1,910		3,220	4,500	5,810	7,110	8,400	
		76~100	2,150		3,840	5,390	6,930	8,490	10,030	
		51~75	2,280		3,790	5,290	6,800	8,310	9,830	
		76~100	2,540		4,260	5,980	7,690	9,400	11,110	
		101~125	2,760		4,540	6,330	8,110	9,890	11,660	
		76~100	2,930		4,870	6,830	8,770	10,710	12,650	
		101~125	3,150		5,170	7,190	9,200	11,210	13,230	
	101~125	3,360	5,450		7,530	9,610	11,700	13,780		

型式 Type	T	A	B	L	¥基準単価					
					最短L~50	L51~100	L101~150	L151~200	L201~250	L251~300
LAAR (A6063)	5	20~50	20~50	25~300	1,060	1,910	2,760	3,620	4,470	5,320
		51~75			1,380	2,410	3,450	4,480	5,520	6,560
	6	51~75	1,620		2,760	3,890	5,030	6,150	7,290	
		30~50	1,060		1,910	2,760	3,620	4,470	5,320	
		51~75	1,380		2,410	3,450	4,480	5,520	6,560	
		50	1,410		2,420	3,420	4,430	5,420	6,440	
		51~75	1,880		3,120	4,350	5,590	6,830	8,050	
		76~100	2,070		3,300	4,550	5,810	7,060	8,290	
		51~75	2,190		3,570	4,960	6,390	7,720	9,100	
		76~100	2,480		4,010	5,520	7,030	8,520	10,060	
	76~100	2,700	4,270		5,850	7,400	8,970	10,550		

型式 Type	T	A	B	L	¥基準単価					
					最短L~50	L51~100	L101~150	L151~200	L201~250	L251~300
LAUR (SUS304)	5	20~60	25~50	25~300	2,880	5,260	7,650	10,020	12,420	14,800
	6	60~75	25~50		3,070	5,580	8,080	10,580	13,090	15,590
		51~75	3,330		5,920	8,520	11,110	13,700	16,300	
	8	50	3,400		6,150	8,900	11,640	14,400	17,150	
51~75		4,120	7,030	9,960	12,880	15,780	18,700			

Order 注文例: 型式 - A - B - L
LASR10 - A100 - B100 - L300

Price 価格

数量区分	標準対価	個別対価
1~9	10~19	20~50
10~19	5%	10%
20~50	5%	10%
51~	5%	10%

◎表示数量超えはWOSにてご確認ください。

Delivery 出荷日: 3 日目出荷

Alteration 追加加工: 型式 - A - B - L - (CKC・CCA・CCB-etc.)
LASR10 - A100 - B100 - L300 - CKC

Alterations	コーナーカット	側面直角度保証
Code	CCA・CCB・CCC・CCD	CKC
Spec.	任意のコーナーをカットすることができます。1≦コーナーカット≦30 1mm単位指定 指定方法 (例) AとDのコーナーをC5でカットする場合→CCA5~CCD5	A面に対するL寸法両面の直角加工をします。 指定方法 CKC
¥/Code	Spec.参照	800

L型アンゲル

一面切削内側未仕上直角度外側基準フリー指定タイプ



材料屋24でミスミ型番・出荷日・価格を一発表示! (<http://misumi.jp/fa24>)

CADデータフォルダ名: 59_Angles



Type	材質
LSS	SS400
LSA	A6063

◎V部、SS400はショットブラスト処理
◎A6063は引抜素材の地肌のままです。

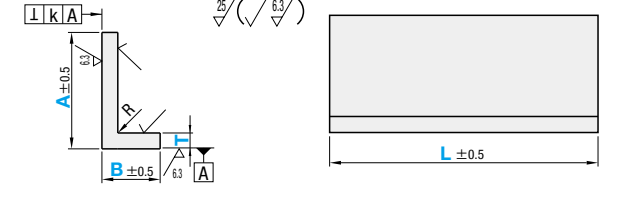

型式 Type	T	T公差	指定1mm単位		
			A	B	L
LSS	5	±0.5	25~75	25~75	25~300
	6		25~125	25~125	
	10		101~150	101~150	
	15		151~175	151~175	
LSA	5	±0.5	25~75	25~75	25~300
	6		25~125	25~125	
	10		101~125	101~125	
	12		101~125	101~125	

A・B寸法の長手	直角度k
25~80	0.05以内
81~150	0.10以内
151~175	0.15以内

A・B寸法の長手	T	LSS	LSA
25~60	5	8.5~10	1以下
61~75			6~8
25~50	6	10~14	8~9
51~75			10~12
25~60			10~14
61~150	15	16~18	—
151~175			—

型式	A	B	¥基準単価																									
			LSS5・LSS6						LSS10						LSS12						LSS15							
LSS5 LSS6 LSS10 LSS12 LSS15	25~50	25~50	L25~50	L51~100	L101~150	L151~200	L201~250	L251~300	L25~50	L51~100	L101~150	L151~200	L201~250	L251~300	L25~50	L51~100	L101~150	L151~200	L201~250	L251~300	L25~50	L51~100	L101~150	L151~200	L201~250	L251~300		
			1,180	2,080	2,990	3,930	4,840	5,770	1,580	2,730	3,930	5,130	6,340	7,550	—	—	—	—	—	—	—	—	—	—	—	—	—	
			1,580	2,740	3,960	5,180	6,400	7,610	1,750	3,000	4,290	5,510	6,890	8,110	—	—	—	—	—	—	—	—	—	—	—	—	—	—
			—	—	—	—	—	—	2,050	3,610	5,150	6,710	8,260	9,820	—	—	—	—	—	—	—	—	—	—	—	—	—	—
	51~75	51~75	1,580	2,740	3,960	5,180	6,400	7,610	1,750	3,000	4,290	5,510	6,890	8,110	—	—	—	—	—	—	—	—	—	—	—	—	—	
			1,760	3,020	4,340	5,640	6,940	8,170	1,960	3,470	4,980	6,490	8,010	9,510	—	—	—	—	—	—	—	—	—	—	—	—	—	—
			—	—	—	—	—	—	2,300	4,100	5,890	7,690	9,480	11,190	—	—	—	—	—	—	—	—	—	—	—	—	—	—
			—	—	—	—	—	—	2,630	4,660	6,690	8,740	10,770	12,820	—	—	—	—	—	—	—	—	—	—	—	—	—	—
	76~100	76~100	—	—	—	—	—	—	2,050	3,610	5,150	6,710	8,260	9,820	—	—	—	—	—	—	—	—	—	—	—	—	—	
			—	—	—	—	—	—	2,300	4,100	5,890	7,690	9,480	11,190	—	—	—	—	—	—	—	—	—	—	—	—	—	
			—	—	—	—	—	—	2,510	4,530	6,460	8,400	10,350	12,280	—	—	—	—	—	—	—	—	—	—	—	—	—	
			—	—	—	—	—	—	2,740	4,880	7,010	9,140	11,430	13,400	—	—	—	—	—	—	—	—	—	—	—	—	—	—
101~125	101~125	—	—	—	—	—	—	2,400	4,270	6,150	8,060	9,900	11,690	—	—	—	—	—	—	—	—	—	—	—	—	—		
		—	—	—	—	—	—	2,630	4,660	6,690	8,740	10,770	12,820	—	—	—	—	—	—	—	—	—	—	—	—	—		
		—	—	—	—	—	—	2,740	4,880	7,010	9,140	11,430	13,400	—	—	—	—	—	—	—	—	—	—	—	—	—		
		—	—	—	—	—	—	2,900	5,130	7,380	9,610	11,860	14,100	5,700	9,990	13,420	16,750	21,190	25,020	—	—	—	—	—	—	—	—	
126~150	126~150	—	—	—	—	—	—	—	—	—	—	—	—	—	—	—	—	—	—	—	—	—	—	—	—	—		
		—	—	—	—	—	—	—	—	—	—	—	—	—	—	—	—	—	—	—	—	—	—	—	—	—		
		—	—	—	—	—	—	—	—	—	—	—	—	—	—	—	—	—	—	—	—	—	—	—	—	—	—	
		—	—	—	—	—	—	—	—	—	—	—	—	—	—	—	—	—	—	—	—	—	—	—	—	—	—	
151~175	151~175	—	—	—	—	—	—	—	—	—	—	—	—	—	—	—	—	—	—	—	—	—	—	—	—	—		
		—	—	—	—	—	—	—	—	—	—	—	—	—	—	—	—	—	—	—	—	—	—	—	—	—		
		—	—	—	—	—	—	—	—	—	—	—	—	—	—	—	—	—	—	—	—	—	—	—	—	—	—	
		—	—	—	—	—	—	—	—	—	—	—	—	—	—	—	—	—	—	—	—	—	—	—	—	—	—	

型式	A	B	¥基準単価																							
			LSA5・LSA6						LSA10						LSA12											
LSA5 LSA6 LSA10 LSA12	25~50	25~50	L25~50	L51~100	L101~150	L151~200	L201~250	L251~300	L25~50	L51~100	L101~150	L151~200	L201~250	L251~300	L25~50	L51~100	L101~150	L151~200	L201~250	L251~300	L25~50	L51~100	L101~150	L151~200	L201~250	L251~300
			1,150	2,030																						

L型アングル 価格表

一面切削外側基準フリー指定タイプ 価格



L型アングル

一面切削直角度外側基準板厚フリー指定タイプ



材料屋24でミスミ型番・出荷日・価格を一発表示! (<http://misumi.jp/fa24>)

CADデータフォルダ名: 59_Angles

型式	T	A	B	¥基準単価															
				最短L~50	L51~100	L101~150	L151~200	L201~250	L251~300	L301~325	L326~350	L351~375	L376~400	L401~425	L426~450	L451~475	L476~500		
LASC (S50C)	5	20~50	20~50	2,650	3,690	4,740	6,220	7,270	8,610										
			51~70	2,820	4,020	5,210	6,850	8,050	9,540										
		51~75	20~50	2,820	4,020	5,210	6,850	8,050	9,540										
			51~70	3,660	5,580	7,510	9,880	11,810	14,030										
		6	20~50	2,630	3,660	4,690	6,150	7,180	8,510										
			51~70	2,820	4,020	5,210	6,850	8,050	9,540										
	10	25~50	20~50	2,820	4,020	5,210	6,850	8,050	9,540										
			51~70	3,660	5,580	7,510	9,880	11,810	14,030										
		51~75	25~50	2,630	3,660	4,690	6,150	7,180	8,510	9,020	9,540	10,050	11,140	11,650	12,170	12,680	13,780		
			51~70	3,660	5,580	7,510	9,880	11,810	14,030	14,990	15,960	16,920	18,460	19,430	20,390	21,360	22,900		
		76~100	25~50	3,990	6,210	8,440	11,100	13,330	15,850	16,960	18,070	19,190	20,870	21,980	23,100	24,210	25,900		
			51~70	4,370	6,920	9,480	12,470	15,030	17,880	19,150	20,430	21,710	23,570	24,840	26,120	27,400	29,260		
12	50	50	2,920	3,950	4,980	6,440	7,480	8,790	9,310	9,820	10,340	11,430	11,950	12,460	12,980	14,070			
		51~70	3,940	5,870	7,810	10,170	12,090	14,310	15,280	16,240	17,210	18,750	19,720	20,690	21,640	23,190			
	51~75	50	3,940	5,870	7,810	10,170	12,090	14,310	15,280	16,240	17,210	18,750	19,720	20,690	21,640	23,190			
		50	4,250	6,440	8,640	11,270	13,460	15,960	17,050	18,150	19,250	20,930	22,020	23,120	24,220	25,890			
	101~125	50	4,660	7,220	9,780	12,770	15,320	18,170	19,440	20,720	22,000	23,860	25,140	26,420	27,690	29,550			
		50	3,060	4,090	5,120	6,580	7,610	8,940	9,450	9,970	10,480	11,720	12,230	12,750	13,260	14,360			
15	51~75	50	4,090	6,020	7,940	10,310	12,240	14,460	15,420	16,390	17,360	19,040	20,010	20,970	21,940	23,480			
		50	4,090	6,020	7,940	10,310	12,240	14,460	15,420	16,390	17,360	19,040	20,010	20,970	21,940	23,480			
	76~100	50	4,390	6,590	8,780	11,410	13,160	15,400	17,200	18,290	19,390	21,210	22,310	23,410	24,510	26,190			
101~125	50	4,810	7,360	9,910	12,900	15,460	18,310	19,590	20,870	22,150	24,150	25,420	26,700	27,980	29,840				

型式	T	A	B	¥基準単価															
				最短L~50	L51~100	L101~150	L151~200	L201~250	L251~300	L301~325	L326~350	L351~375	L376~400	L401~425	L426~450	L451~475	L476~500		
LAA (A6063)	5・6	20~50	20~50	1,330	2,340	3,360	4,390	5,410	6,360										
			51~75	1,740	3,070	4,370	5,680	7,000	8,230										
		20~50	51~75	1,660	2,910	4,170	5,430	6,690	7,870										
			51~75	1,940	3,350	4,770	6,190	7,600	8,950										
		10	25~50	1,740	3,100	4,470	5,810	7,180	8,450										
			51~75	2,150	3,810	5,480	7,150	8,830	10,370										
	12	76~100	25~50	2,200	3,910	5,620	7,330	9,030	10,620										
			25~50	2,060	3,670	5,290	6,900	8,520	10,020										
		51~75	76~100	2,480	4,440	6,400	8,370	10,340	12,170	13,800	14,720	15,800	16,730	17,820	18,740	19,810	20,730		
			76~100	2,740	4,950	7,130	9,320	11,520	13,560	15,980	16,990	18,180	19,200	20,390	21,400	22,600	23,610		
		101~125	76~100	2,150	3,810	5,480	7,150	8,830	10,370										
			76~100	2,740	4,950	7,130	9,320	11,520	13,560	15,980	16,990	18,180	19,200	20,390	21,400	22,600	23,610		
15	50~75	76~100	6,350	9,730	13,170	16,620	20,050	23,490	26,210	27,260	29,920	31,700	33,640	35,420	37,370	39,140			
		76~100	7,110	10,900	14,720	18,580	22,420	26,260	30,520	32,570	34,780	36,820	39,030	41,070	43,280	45,320			
	101~125	76~100	7,700	11,810	15,930	20,060	24,190	28,330	33,500	35,710	38,070	40,280	42,670	44,870	47,240	49,450			
		76~100	7,110	10,900	14,720	18,580	22,440	26,260	30,520	32,570	34,780	36,820	39,030	41,070	43,280	45,320			
	12	76~100	7,610	11,660	15,650	19,660	23,640	27,610	31,340	33,390	35,600	37,630	39,840	41,890	44,100	46,150			
		101~125	8,160	12,510	16,740	20,980	25,210	29,440	34,320	36,530	38,900	41,110	43,470	45,680	48,070	50,270			
15	50~75	101~125	7,760	11,900	16,000	20,100	24,240	28,290	33,500	35,710	38,070	40,280	42,670	44,870	47,240	49,450			
		101~125	8,160	12,510	16,740	20,980	25,210	29,440	34,320	36,530	38,900	41,110	43,470	45,680	48,070	50,270			
	101~125	8,530	13,080	17,420	21,770	26,110	30,460	35,130	37,340	39,720	41,930	44,290	46,500	48,880	51,080				
15	100~125	7,480	11,490	15,510	19,510	23,520	27,530	32,590	34,530	36,650	38,600	40,710	42,660	44,770	46,730				
	126~150	7,910	12,150	16,400	20,640	24,900	29,150	34,900	36,970	39,200	41,270	43,480	45,540	47,780	49,850				
126~150	8,370	12,870	17,370	21,860	26,370	30,870	37,410	39,590	41,960	44,150	46,510	48,690	51,050	53,240					

型式	T	A	B	¥基準単価					
				最短L~50	L51~100	L101~150	L151~200	L201~250	L251~300
LAU (SUS304)	5・6	25~50	25~50	2,970	5,380	7,820	10,230	13,010	15,380
			51~75	3,520	6,360	9,290	12,130	14,730	17,550
		76~90	25~50					17,880	21,220
			51~75	3,520	6,360	9,290	12,130	14,730	17,550
		76~90	51~75	3,720	6,670	9,600	12,540	15,450	18,370
			76~90					18,340	21,710
	8	25~50	76~90	4,520	7,860	11,200	14,540	17,880	21,220
			51~75	4,850	8,230	11,600	14,960	18,340	21,710
		76~90	25~50	5,290	8,690	12,090	15,490	18,890	22,300
			51~75	3,300	5,970	8,630	11,300	16,160	19,230
		76~90	25~50	3,690	6,610	9,530	12,430	17,200	20,420
			76~90					18,100	21,430
10	25~50	76~90	3,690	6,610	9,530	12,430	17,200	20,420	
		51~75	3,930	6,940	9,980	13,030	17,760	21,010	
	76~90	25~50					18,670	22,020	
		51~75	4,820	8,100	11,450	14,780	18,100	21,430	
	76~90	50~75	5,240	8,600	11,960	15,300	18,670	22,020	
		76~90	5,670	9,060	12,430	15,830	19,220	22,610	
10	50~75	50~75	6,440	10,820	15,180	19,560	23,920	28,300	
		76~100	7,240	11,970	16,740	21,480	26,230	30,980	
	76~100	50~75	7,240	11,970	16,740	21,480	26,230	30,980	
		76~100	7,710	12,740	17,580	22,420	27,250	32,090	

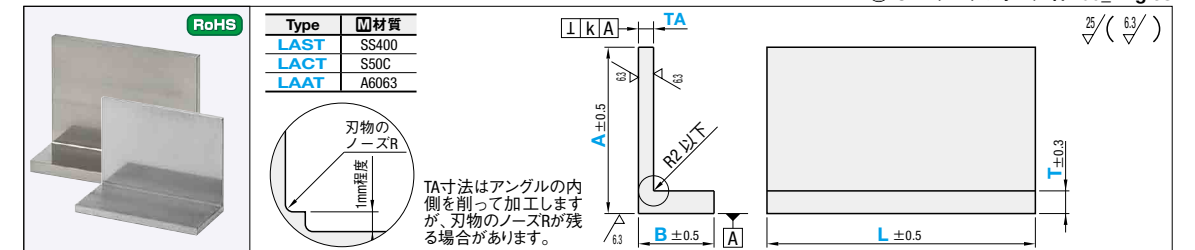

型式	指定1mm単位	A	B	L
LAST	20~75	20~75	20~75	25~200
LACT	10.5~15.0	20~150	20~150	25~300
LAAT	10.5~12.0	20~125	20~70	25~300

A・B寸法 直角度 k
 20~75 0.05以内
 76~125 0.1以内
 126~150 0.2以内

数量スライド価格 (円未満切り捨て) P127
 数量区分: 標準対応 (小口), 特別対応 (大口)
 数量: 1~9, 10~19, 20~50, 51~
 値引率: 標準単価 5%, 10%, お見積り

型式	A	B	¥基準単価																							
			T・TA4~6				T・TA6.5~10				T・TA10.5~12				T・TA12.5~15											
LAST (SS400)	20~50	20~50	最短L~50	L51~100	L101~150	L151~200	最短L~50	L51~100	L101~150	L151~200	最短L~50	L51~100	L101~150	L151~200	L201~250	L251~300	L301~325	L326~350	L351~375	L376~400	L401~425	L426~450	L451~475	L476~500		
			3,160	5,120	7,060	8,850	3,990	6,330	8,650	11,010	6,290	9,490	12,710	15,920	19,140	22,360	25,580	28,800	32,020	35,240	38,460	41,680	44,900	48,120	51,340	
		51~75	20~50	3,900	6,210	8,530	10,850	4,940	7,460	9,950	12,510	7,180	10,650	14,120	17,590	21,050	24,510	27,970	31,430	34,890	38,350	41,810	45,270	48,730	52,190	55,650
			51~75	7,550	11,040	14,540	18,050	21,560	25,070	28,580	32,090	35,600	39,110	42,620	46,130	49,640	53,150	56,660	60,170	63,680	67,190	70,700	74,210	77,720	81,230	84,740
		76~100	20~50																							

L型表面処理アンゲル

一面切削直角度外側基準フリー指定タイプ

材料屋24でミスミ型番・出荷日・価格を一発表示! (<http://misumi.jp/fa24>)

材料屋 24 アンゲル・形鋼材

プライスダウン

値下げ価格

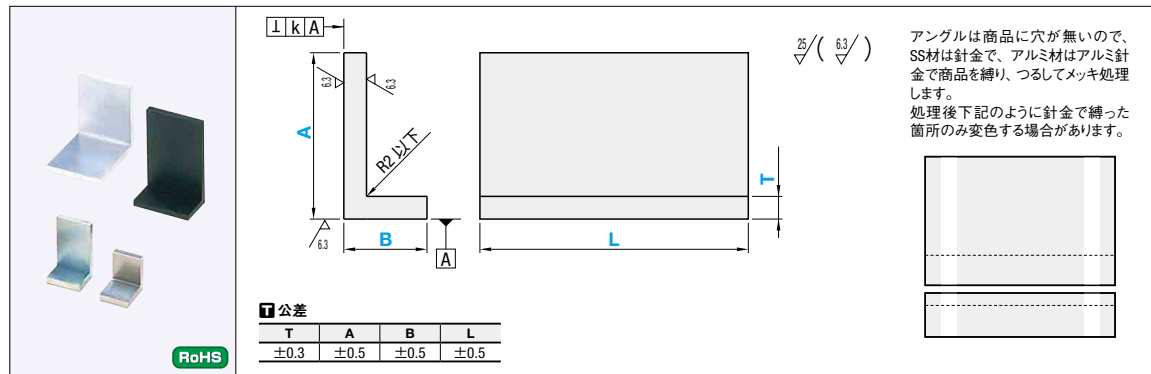

アンゲルは商品に穴が無いので、SS材は針金で、AL材はアルミ針金で商品を縛り、つるしてメッキ処理します。
処理後下記のように針金で縛った箇所のみ変色する場合があります。

材質	表面処理	Code
SS400	四三酸化鉄皮膜	BLAS
	無電解ニッケルメッキ	MLAS
	ユニクロメッキ	YLAS
A6063	三価クロメート	SLAS
	アルマイト(白色)	WLAA
	アルマイト(黒色)	ELAA

T寸法	A・B寸法の長手	直角度k
5・6	最小～75	0.05
10	最小～80	0.05
12・15	81～125	0.1
	最小～80	0.05
15	81～125	0.1
15	126～150	0.35

Type	T	A	B	L
BLAS MLAS YLAS SLAS	5	20～75	20～75	25～300
	6			
	10	25～125	25～125	
	12	50～125	50～125	
WLAA ELAA	5	20～75	20～75	25～300
	6			
5	10	25～100	25～100	50～300
	12	50～125	50～125	
	15	50～150	50～150	

Order 注文例: 型式 BLAS10 - A75 - B50 - L100

Price 価格: 数量スライド価格 (1円未満切り捨て) P:127

数量区分	標準対応	個別対応
数量	1~9	10~19
値引率	基準単価	5%
	10%	お見積り

Alteration 追加加工: 型式 BLAS10 - A120 - B120 - L150 - CKC

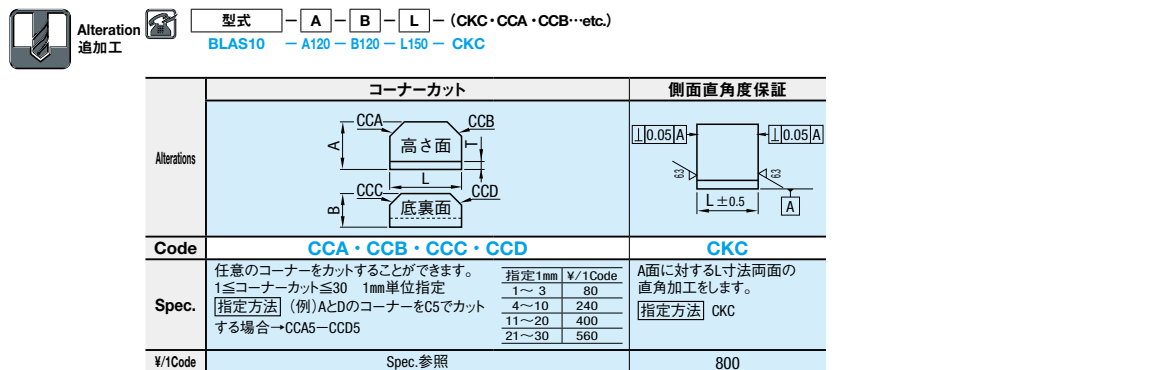

型式	T	A	B	¥基準単価								
5 6 10 12	5	20~50	20~50	最短L~50	L51~100	L101~150	L151~200	L201~250	L251~300			
				51~75	1.810	2.830	4.040	5.280	6.590	7.870		
				20~50	2.210	3.850	5.120	6.760	8.170	9.640		
	6	51~75	20~50	20~50	2.400	4.130	5.820	7.570	9.330	10.970		
					25~50	2.040	3.560	5.090	6.650	8.200	9.670	
					51~75	2.540	4.440	6.360	8.770	10.280	12.080	
	10	25~50	51~75	20~50	2.660	4.600	6.550	8.530	10.540	12.400		
					51~75	3.080	5.370	7.650	10.000	12.330	14.540	
					76~100	2.530	4.410	6.310	8.250	10.180	11.980	
	12	51~75	76~100	51~75	2.920	5.090	7.250	9.500	11.740	13.820		
					76~100	3.170	5.510	7.870	10.300	12.730	14.960	
					101~125	3.500	6.080	8.680	10.880	14.050	16.540	
15	25~50	101~125	76~100	2.660	4.600	6.550	8.530	10.540	12.400			
				51~75	3.170	5.510	7.870	10.300	12.730	14.960		
				76~100	3.290	5.660	8.090	10.590	13.060	15.330		
101~125	76~100	101~125	76~100	3.620	6.250	8.900	11.640	14.400	16.940			
				25~50	3.080	5.370	7.650	10.000	12.330	14.540		
				51~75	3.500	6.080	8.680	10.880	14.050	16.540		
76~100	101~125	101~125	101~125	3.750	6.450	9.130	11.920	14.740	17.340			
				50	8.590	8.370	11.760	14.220	16.910	19.790		
				51~75	9.940	9.590	12.630	15.770	18.680	22.000		
76~100	50	101~125	50	10.830	10.530	14.870	17.290	20.740	24.110			
				101~125	12.040	11.710	15.450	19.240	23.070	26.870		
				50	9.660	9.410	12.480	15.600	18.720	21.840		
51~75	51~75	76~100	51~75	10.470	10.180	13.420	16.750	20.070	23.380			
				76~100	11.390	11.070	14.570	18.140	21.720	25.300		
				101~125	12.900	12.540	16.090	19.980	23.900	27.800		
101~125	76~100	101~125	76~100	10.830	10.530	13.870	17.230	20.700	24.170			
				76~100	14.920	13.880	18.190	22.630	27.080	31.520		
				50	10.560	10.310	13.830	17.380	20.930	24.470		
51~75	50	101~125	50	11.700	11.420	15.210	19.040	22.720	26.580			
				76~100	12.860	12.530	16.610	20.730	24.870	29.010		
				101~125	14.060	13.700	18.070	22.510	26.600	31.390		
50	51~75	76~100	50	11.700	11.420	15.210	19.040	22.720	26.580			
				51~75	12.360	12.050	15.980	19.930	23.760	27.740		
				76~100	13.450	13.080	17.330	21.360	25.940	30.260		
101~125	76~100	101~125	76~100	15.250	14.860	19.540	24.320	29.090	33.870			
				50	7.480	7.150	9.570	12.400	15.230	18.060		
				51~75	12.860	12.530	16.610	20.730	24.870	29.010		
76~100	76~100	101~125	76~100	13.450	13.080	17.330	21.360	25.940	30.260			
				101~125	14.840	14.410	19.090	23.700	28.660	31.790		
				126~150	15.730	15.300	20.240	25.300	30.330	35.390		
126~150	126~150	126~150	126~150	16.810	16.400	20.950	27.090	32.520	37.940			
				51~75	12.040	11.930	16.030	20.330	24.360	28.390		
				76~100	20.630	20.520	26.970	33.520	40.080	46.660		
101~125	126~150	126~150	126~150	21.390	21.280	27.770	34.410	41.650	47.710			
				126~150	22.180	22.060	29.530	37.330	45.040	51.160		

型式	T	A	B	¥基準単価								
5 6 10 12	5	20~50	20~50	最短L~50	L51~100	L101~150	L151~200	L201~250	L251~300			
				51~75	1.740	3.050	4.330	5.670	6.980	8.240		
				20~50	2.370	4.120	5.820	7.600	9.370	11.040		
	6	51~75	20~50	20~50	2.180	3.810	5.410	7.070	8.730	10.310		
					25~50	2.580	4.410	6.190	8.060	9.940	11.700	
					51~75	2.180	3.790	5.400	7.070	8.730	10.290	
	10	25~50	51~75	20~50	2.710	4.700	6.720	9.270	10.890	12.800		
					51~75	2.850	4.870	6.890	9.880	11.120	13.090	
					76~100	3.290	5.650	8.020	10.510	12.970	15.300	
	12	50	101~125	50	2.680	4.670	6.660	8.730	10.780	12.690		
					51~75	3.110	5.360	7.630	10.010	12.390	14.580	
					76~100	3.390	5.810	8.120	10.710	12.910	15.770	
50	51~75	76~100	50	3.740	6.400	9.090	11.420	14.770	17.400			
				51~75	2.850	4.870	6.890	9.880	11.120	13.090		
				76~100	3.390	5.810	8.270	10.830	13.410	15.770		
76~100	76~100	101~125	76~100	3.530	6.000	8.510	11.150	13.790	16.230			
				101~125	3.880	6.600	9.320	12.220	15.140	17.820		
				25~50	3.290	5.650	8.020	10.510	12.970	15.300		
101~125	76~100	101~125	76~100	3.740	6.400	9.090	11.420	14.770	17.400			
				50	4.030	6.820	9.580	12.520	15.500	18.250		
				51~75	9.050	8.670	12.190	14.760	17.590	20.600		
76~100	50	101~125	50	10.350	9.920	13.060	16.350	19.600	22.850			
				101~125	11.430	10.920	14.370	17.950	21.520	25.090		
				76~100	11.430	10.920	14.370	17.950	21.520	25.090		
50	51~75	76~100	50	13.620	13.000	16.650	20.720	24.800	28.880			
				76~100	11.430	10.920	14.370	17.950	21.520	25.090		
				101~125	12.040	11.500	15.110	18.840	22.590	26.330		
76~100	76~100	101~125	76~100	13.620	13.000	16.650	20.720	24.800	28.880			
				101~125	14.140	13.450	17.630	21.990	26.330	30.680		
				126~150	15.270	14.510	18.990	23.700	28.400	33.990		
126~150	126~150	126~150	126~150	11.060	10.620	14.250	17.910	21.630	25.290			
				51~75	12.320	11.750	15.840	19.690	23.620	27.400		
				76~100	13.470	12.820	17.100	21.380	25.680	29.880		
50	51~75	76~100	50	14.720	14.120	18.600	23.200	26.420	32.400			
				76~100	12.230	11.750	15.640	19.600	23.420	27.400		
				101~125	12.960	12.440	16.460	20.560	24.540	28.670		
76~100	76~100	101~125	76~100	14.140	13.530	17.890	22.080	26.840	31.330			
				101~125	16.020	15.350	20.150	25.110	30.070	35.040		
				50	7.840	7.130	9.840	12.820	15.960	19.300		
50	51~75	76~100	50	13.470	12.820	17.100	21.380	25.680	29.880			
				76~100	14.140	13.530	17.890	22.080	26.840	31.330		
				101~125	15.670	14.940	19.760	24.570	29.740	34.020		
126~150	126~150	126~150	126~150	16.580	15.850	20.940	26.210	31.470	36.750			
				50	8.380	7.840	10.500	13.360	16.640	19.920</		



材料屋24でミスミ型番・出荷日・価格を一発表示! (<http://misumi.jp/fa24>)

CADデータフォルダ名: 59_Angles

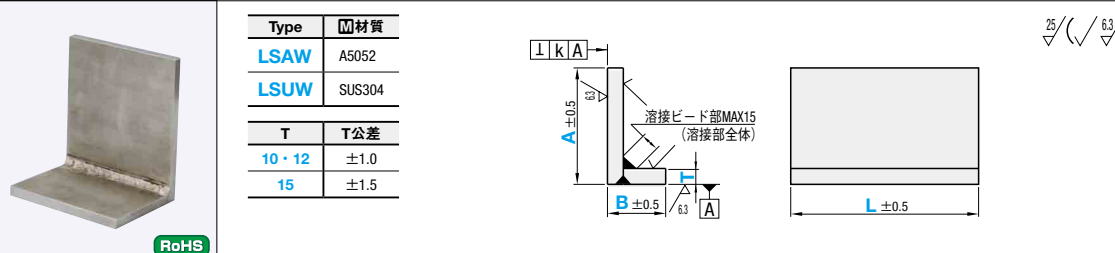

Type	材質
LSAW	A5052
LSUW	SUS304

T	T公差
10・12	±1.0
15	±1.5

型式	A	B	¥基準単価											
			LSAW10			LSAW12			LSAW15					
			L50~100	L101~150	L151~200	L50~100	L101~150	L151~200	L50~100	L101~150	L151~200	L201~250	L251~300	
LSAW10 LSAW12 LSAW15	101~125	101~125	8,240	10,440	12,310	9,400	11,840	13,920	9,750	12,310	14,510	17,410	19,960	
			8,590	10,910	12,880	9,640	12,190	14,400	10,320	13,120	15,440	18,460	21,010	
									11,020	13,810	16,360	19,510	22,170	
	126~150	126~150	8,590	10,910	12,880	9,640	12,190	14,400	10,320	13,120	15,440	18,460	20,890	
			8,930	11,260	13,240	9,980	12,530	14,740	11,020	13,810	16,360	19,510	22,170	
									11,720	14,860	17,410	20,780	23,560	
	151~175	151~175							12,650	15,910	18,570	22,170	25,080	
									11,020	13,810	16,360	19,510	22,170	
									11,720	14,860	17,410	20,780	23,560	
									12,650	15,910	18,570	22,170	25,080	
176~200	176~200							13,460	16,950	19,850	23,560	26,590		
								11,950	14,970	17,640	21,010	23,800		
								12,650	15,910	18,570	22,170	25,080		
								13,460	16,950	19,850	23,560	26,590		

型式	A	B	¥基準単価								
			LSUW10		LSUW12		LSUW15				
			L50~100	L101~150	L151~200	L50~100	L101~150	L151~200	L50~100	L101~150	L151~200
LSUW10 LSUW12 LSUW15	76~100	76~100	11,140	14,620	17,520	12,310	16,250	19,390			
			11,840	15,550	18,460	13,120	17,290	20,780			
			12,650	16,720	19,850	14,040	18,460	22,060			
	101~125	101~125	11,840	15,550	18,460	13,120	17,290	20,780			
			12,650	16,720	19,850	14,040	18,460	22,060	15,320	20,080	24,150
			13,580	17,880	21,240	14,970	19,730	23,450	16,130	21,480	25,890
	126~150	126~150							17,060	22,750	27,520
									18,000	24,150	29,020
									16,130	21,480	25,890
									17,520	23,450	28,320
151~175	151~175							18,460	24,720	30,070	
								19,150	25,770	31,350	
								18,000	24,150	29,020	
								19,690	25,080	30,420	
176~200	176~200							19,150	25,770	31,350	
								19,960	26,710	32,620	
								18,690	24,720	30,070	
								19,690	25,080	30,420	

A・B寸法の長手	直角度k
76~150	0.10以内
151~200	0.15以内

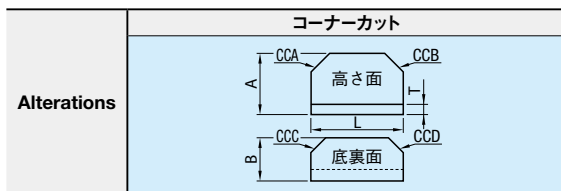

Code	CCA・CCB・CCC・CCD
Spec.	任意のコーナーをカットすることができます。 1≦コーナーカット≦30 1mm単位指定 指定1mm ¥/1Code 1~3 80 4~10 240 11~20 400 21~30 560 指定方法 (例)AとDのコーナーをC5でカットする場合→CCA5-CCD5

Order 注文例 **型式** - A - B - L
LSAW10 - A120 - B120 - L150

Delivery 出荷日 **5** 日目出荷

Alteration 追加加工 **型式** - A - B - L - (CKC・SR・WR...etc.)
LSAW10 - A120 - B120 - L150 - WR60

Alterations	Code	Spec.	¥/1Code
	CKC	A面に対するL寸法両面の直角加工をします。 指定方法 CKC	LSAW LSUW 1,200
	SR	L寸法のセンターにt6mmのリップを追加溶接します。 SR≧A/2 指定方法 SR80 (リップの高さ=底面より80mm)	LSAW LSUW 2,200 4,000
	WR	L寸法両側より2mm内側にt6mmのリップを2コ追加溶接します。 WR≧A/2 指定方法 WR70 (リップの高さ=底面より70mm)	LSAW LSUW 4,100 6,200

Price 価格 **数量スライド価格** (☉1円未満切り捨て) P:127

数量区分	標準対応	個別対応		
数量	1~9	10~19	20~50	51~
値引率	基準単価	5%	10%	お見積り

☉表示数量超えはWOSにてご確認ください。

材料屋24でミスミ型番・出荷日・価格を一発表示! (<http://misumi.jp/fa24>)

CADデータフォルダ名: 59_Angles

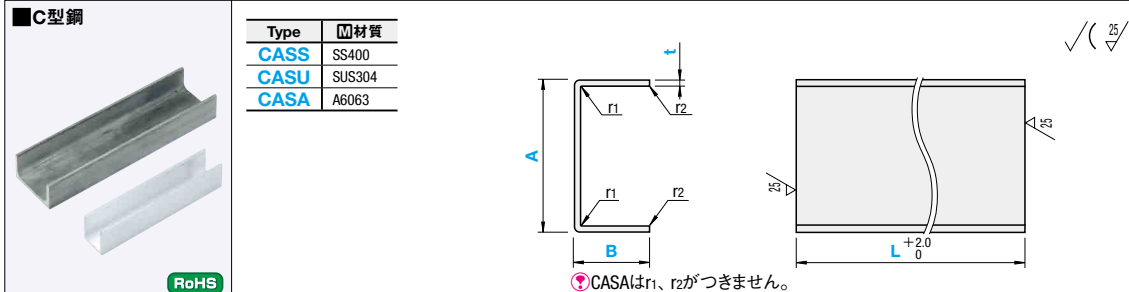

Type	材質
CASS	SS400
CASU	SUS304
CASA	A6063

☉CASAはr1, r2がつきません。

型式	Type	t	A-B	L 指定1mm単位	t公差	A		B		(r1)	(r2)	¥基準単価					
						公差	公差	公差	公差			L30~100	L101~200	L201~400	L401~600	L601~800	L801~1000
CASS	3	2.3	4020	30~1000	±0.25	40	±1.5	20	±1.5	4	2	1,290	1,260	1,550	1,620	2,030	2,020
						80	±1.5	40	±1.5	8	2	1,860	1,920	2,400	2,520	3,190	3,210
						40	±1.5	20	±1.5	4	2	1,820	2,330	3,590	4,590	5,970	6,970
CASU	5	8040	30~1000	±0.4	80	±2.0	40	±1.5	4.5	3	4,340	5,950	9,640	12,080	15,820	18,800	
					±0.23	15	±0.35	15	±0.35	—	—	650	710	910	970	1,240	1,300
CASA	2	2525	30~1000	±0.23	25	±0.38	25	±0.38	—	—	660	730	950	1,030	1,330	1,400	
					20	±0.38	20	±0.38	—	—	680	770	970	1,130	1,450	1,560	
	3	5025	30~1000	±0.23	50	±0.54	25	±0.38	—	—	690	790	1,000	1,180	1,530	1,650	
					40	±0.54	20	±0.38	—	—	860	960	1,250	1,440	1,860	1,980	
					60	±0.92	30	±0.45	—	—	1,050	1,200	1,680	1,980	2,550	2,750	
4	8040	30~1000	±0.27	80	±0.92	40	±0.54	—	—	1,350	1,620	2,290	2,810	3,640	4,150		
				75	±0.92	50	±0.54	—	—	1,450	1,810	2,660	3,350	4,360	5,060		

Order 注文例 **型式** - A-B - L
CASA2 - 2525 - 400

Alteration 追加加工 **型式** - A-B - L - (NC)
CASA2 - 2525 - 400 - NC3-J10-P80-K3

Delivery 出荷日 **3** 日目出荷

Price 価格 **数量スライド価格** (☉1円未満切り捨て) P:127

数量区分	標準対応	個別対応		
数量	1~9	10~19	20~50	51~
値引率	基準単価	5%	10%	お見積り

☉表示数量超えはWOSにてご確認ください。

Alteration	Code	Spec.	¥/1Code
取付穴追加加工	NC	NC:適用ボルトサイズ J:指定1mm単位 P:ピッチ指定1mm単位 K:穴数 指定方法 NC3-J10-P80-K3	CASA 500 CASS CASU 800
		NC 適用ボルト N	
		3 M3 φ3.5	
		4 M4 φ4.5	
		5 M5 φ5.5	

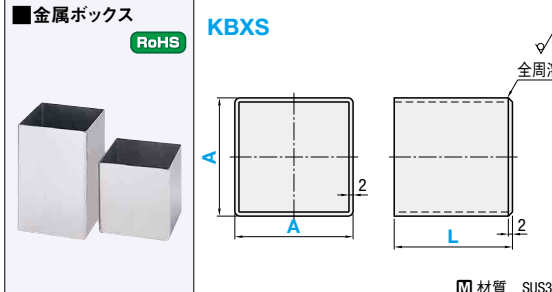

☉材質 SUS304

型式	Type	A	L	¥基準単価
KBXS	50	50	50	2,000
		75	75	2,170
	75	75	75	2,670
		100	100	3,000
100	100	100	3,950	
	150	150	4,500	

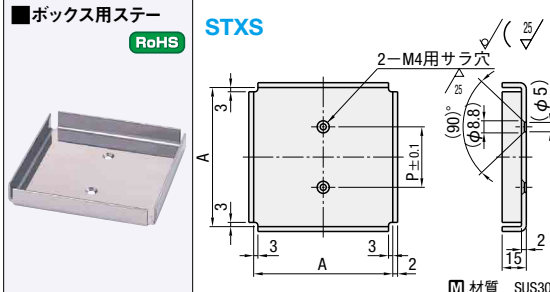

☉材質 SUS304

型式	Type	呼び	A	P	¥基準単価
STXS	50	51	25		1,000
		75	35		1,160
	100	101	45		1,340

Order 注文例 **型式** - L
KBXS75
STXS100

Delivery 出荷日 **在庫品** 翌日出荷 P:127
☉ご希望によりPM6:00迄、当日出荷受付致します。

Price 価格 **数量スライド価格** (☉1円未満切り捨て) P:127

数量区分	標準対応	個別対応			
数量	1~9	10~19	20~49	50~200	201~
値引率	基準単価	5%	10%	18%	お見積り

☉表示数量超えはWOSにてご確認ください。

EX Example 使用例
異品・不良品の払い出し等に
KBXS
STXS

59 形アングル