

# WASHERS COLLARS SHIMS ワッシャ/カラー/シム

ワッシャ・カラー  
シム  
WASHERS  
COLLARS  
SHIMS

追加	追加	追加	追加	追加
在製	在製	在製	在製	在製
製品名	金属ワッシャ-並級/精密級 T寸選択・指定タイプ	-並級/精密級/超精密級 T寸公差選択・寸法フリー指定タイプ	-並級/精密級 寸法フリー指定タイプ	-並級/精密級 内外径公差選択・寸法フリー指定タイプ
ページ	93	94	95	97
追加	追加	追加	追加	追加
在製	在製	在製	在製	在製
製品名	金属ワッシャ-タップタイプ	-ツバ付タイプ	-ザグリ穴タイプ	-皿ボルト用タイプ
ページ	99	100	101	103
追加	追加	追加	追加	追加
在製	在製	在製	在製	在製
製品名	金属ワッシャ-形状選択タイプ	長穴ワッシャ	金属ワッシャ LOWA・SRW・SSWA・T・R・K・W・SW	薄肉金属カラー
ページ	104	104	105	106
追加	追加	追加	追加	追加
在製	在製	在製	在製	在製
製品名	パイプカラー	スペーサ	金属カラー-並級/精密級 L寸固定・L寸指定タイプ	-並級/精密級 寸法フリー指定タイプ
ページ	106	106	107	109
追加	追加	追加	追加	追加
在製	在製	在製	在製	在製
製品名	金属カラー-ツバ付タイプ	並級/精密級	樹脂ワッシャ/樹脂カラー	樹脂カラー-内ねじタイプ
ページ	113	113	116	116
追加	追加	追加	追加	追加
在製	在製	在製	在製	在製
製品名	樹脂ワッシャ-ノズ付タイプ/ツバ付タイプ	樹脂ワッシャ-ザグリ穴タイプ	樹脂カラー-標準タイプ	樹脂カラー-ツバ付タイプ
ページ	117	118	119	121
追加	追加	追加	追加	追加
在製	在製	在製	在製	在製
製品名	セラミックス・ワッシャ/シート/カラー	断熱材 ワッシャ/カラー	ふっ素樹脂・エポキシガラス・PEEK ワッシャ/カラー	樹脂シート
ページ	123	124	125	126

追加	追加	追加	追加
在製	在製	在製	在製
製品名	シムリングバック/シムリング	精密級シムリング/ウェーブワッシャ	角シム-モーターベース用/ピロブロック用
ページ	127	128	129
追加	追加	追加	追加
在製	在製	在製	在製
製品名	-割りタイプ	角シム-キリ欠き穴タイプ	-丸穴タイプ
ページ	130	131	131
追加	追加	追加	追加
在製	在製	在製	在製
製品名	シムプレート-定尺タイプ・フリー指定タイプ	シムテープ	シムテープボックス
ページ	133	134	134



WASHERS -STANDARD TYPE-

# 金属ワッシャ

一並級/精密級 T寸選択・T寸指定タイプ

□: 新価格 □: 値下げ価格

価格改訂

ステンレス・めっき品  
脱脂洗浄サービス  
対応商品詳細は下記URLへ  
http://fa.misumi.jp

類似寸法は加工部品Cナビガイドブック: P.129  
CADデータフォルダ名: 35\_Washers

RoHS

並級 T寸公差±0.1 T寸選択タイプ	精密級 T寸公差±0.01 T寸指定タイプ	材質	S表面処理	H硬度
WSSB TWSSB WASB TWASB	WSSM TWSSM WASM TWASM	S45C	四三酸化鉄皮膜 無電解ニッケルメッキ	—
WSSS TWSSS WAS S TWASS	WSSBH TWSSBH WASBH TWASBH	SUS304	—	—
WSSBH TWSSBH WASBH TWASBH	WSSMH TWSSMH WASMH TWASMH	S45C	四三酸化鉄皮膜 無電解ニッケルメッキ	45~50HRC
WSSSH TWSSSH WASSSH TWASSH	—	SUS420J2	—	—

※S45C焼入タイプは肉厚・長さによって45HRC以下になる場合があります。  
※ステンレス焼入タイプ(WSSSH・WASSH)は焼入により変色する場合があります。

並級 精密級

25/(6.3/1.6/)

※D=16以下 C0.2以下  
D=20以上 C0.5以下

## T寸選択タイプ

型式 Type	D	V 選択	T 選択	¥基準単価											
				並級					精密級						
				WSSB	WSSM	WSSS	WSSBH	WSSMH	WSSSH	WASB	WASM	WASS	WASBH	WASMH	WASSH
一並級 WSSB WSSM WSSS WSSBH WSSMH WSSSH	4	2	1 2	70	95	110	85	110	140	90	100	200	100	110	150
	5	2 3	1 2	90	100	110	—	—	—	120	140	200	—	—	—
	6	2 3 4	1 2	70	95	110	85	110	140	90	100	200	100	110	150
	8	2 3 4 5 6	1.5	90	100	120	—	—	—	120	140	220	—	—	—
	10	2 3 4 5 6 8	1 2 3 5	95	115	125	110	125	170	120	140	240	130	160	190
	12	3 4 5 6 8 10	1.5 2.5	100	120	140	—	—	—	130	150	260	—	—	—
	13	4 5 6 8 10	1 2 3 5	95	115	125	110	125	170	120	140	260	130	160	190
	14	4 5 6 8 10	1.5 2.5	100	115	140	—	—	—	130	150	260	—	—	—
	15	4 5 6 8 10 12	1 2 3 5	110	130	140	125	140	180	130	150	270	140	170	210
	16	4 5 6 8 10 12	1.5	110	130	150	—	—	—	130	150	270	—	—	—
一精密級 WASB WASM WASS WASBH WASMH WASSH	20	4 5 6 8 10 12 15 16	2 3 5	140	150	170	150	155	200	170	200	320	180	220	330
	25	6 8 10 12 15 16 20	1.5 2.5	150	170	190	—	—	—	180	220	350	—	—	—
	30	8 10 12 15 16 20 25	2 3 5	140	160	180	155	170	220	200	250	400	210	270	380
	35	10 12 15 16 20 25	3 5 10	140	190	210	175	200	250	220	300	500	240	320	480
	40	10 12 15 16 20 25 30	3 5 10	160	220	240	175	255	280	270	370	750	300	410	610
	45	10 12 15 16 20 25 30	3 5 10	160	270	300	215	310	360	310	460	800	360	500	710
	50	10 12 15 16 20 25 30	3 5 10	210	320	350	260	370	410	370	630	880	430	670	850
	55	10 12 15 16 20 25 30	3 5 10	210	320	350	260	370	410	370	630	880	430	670	850
	60	15 16 20 25 30	3 5 10	250	380	400	300	440	490	470	790	950	550	850	900

Order 注文例: 型式 - V - T  
WSSB14 - 10 - 5

Delivery 出荷日: 3 日目発送

Price 価格: 数量スライド価格 (1円未満切り捨て) P81

数量 1~9 10~19 20~49 50~99 100~199  
値引率 基準単価 30% 35% 40%

表示数量超過はお見積り

## T寸指定タイプ

型式 Type	D	V 選択	T 指定 0.5mm単位	¥基準単価					
				並級			精密級		
				TWSSB	TWSSM	TWSSS	TWASB	TWASM	TWASS
一並級 TWSSB TWSSM TWSSS	4~10	1.0~2.0	180	180	260	320	320	480	560
	12~20	2.5~5.0	220	230	310	340	350	560	740
	25~30	5.5~10.0	250	270	420	360	390	740	730
	30	1.0~2.0	240	260	410	350	380	730	780
一精密級 TWASB TWASM TWASS	4~10	2.5~5.0	280	300	450	430	470	780	990
	12~20	5.5~10.0	310	340	550	480	520	980	980
	25~30	1.0~2.0	300	330	480	470	510	980	1,110
	30	2.5~5.0	350	380	540	520	570	1,110	1,320

Order 注文例: 型式 - V - T  
TWSSB30 - 8 - 5.5

Delivery 出荷日: 3 日目発送

Price 価格: 数量スライド価格 (1円未満切り捨て) P81

数量 1~9 10~19 20~49 50~99 100~199  
値引率 基準単価 5% 10% 15%

表示数量超過はお見積り

WASHERS -T TOLERANCE SPECIFIED TYPE-

# 金属ワッシャ

一並級/精密級/超精密級 T寸公差選択・寸法フリー指定タイプ

大口  
BIG ORDER

ステンレス・めっき品  
脱脂洗浄サービス  
対応商品詳細は下記URLへ  
http://fa.misumi.jp

類似寸法は加工部品Cナビガイドブック: P.129  
CADデータフォルダ名: 35\_Washers

RoHS

型式	材質	S表面処理	H硬度
AWSC	S45C	—	—
AWSB		四三酸化鉄皮膜	
AWSM		無電解ニッケルメッキ	
AWSS	SUS304	—	45~50HRC
AWSH	SUS420J2	—	

※ステンレス焼入タイプ(AWSSH)は焼入により変色する場合があります。

T寸公差選択表

A	B	C	D	E
±0.005	—	—	—	—
-0.1	SB	-0.01	-0.03	-0.01
+0.3	SC	+0.03	+0.01	0
-0.2	SD	-0.02	-0.02	0
+0.2	SE	+0.02	+0.02	0

※D=16以下 C0.2以下  
D=16.5以上 C0.5以下

## T寸公差選択・寸法フリー指定タイプ

型式	T公差 選択	D	V 指定0.5mm単位	T 指定0.1mm単位	¥基準単価													
					一超精密級 - 公差A				一並級 - 公差B~E				一精密級 - 公差SB~SE					
					AWSC	AWSB	AWSM	AWSH	AWSC	AWSB	AWSM	AWSS	AWSH	AWSC	AWSB	AWSM	AWSS	AWSH
AWSC AWSB AWSM AWSS AWSH	超精密級 A 一並級 B C D E 精密級 SB SC SD SE	3.0~58.0	5.0~10.0 0.5mm単位	1.0~2.9	410	430	450	700	180	190	200	290	380	340	350	370	580	540
				3.0~5.0	480	510	530	820	210	240	260	340	430	390	420	440	670	640
			10.5~20.0 0.5mm単位	1.0~2.9	630	680	720	1,060	290	330	360	440	570	520	560	590	870	830
				3.0~5.0	670	730	790	1,140	300	340	380	480	600	550	600	650	940	890
			21~30 1mm単位	1.0~2.9	790	870	950	1,340	360	420	480	510	640	650	720	780	1,100	1,050
				3.0~5.0	880	960	1,050	1,520	370	460	520	570	720	720	790	860	1,250	1,190
			31~40 1mm単位	1.0~2.9	1,120	1,210	1,300	1,920	460	550	600	710	920	920	1,000	1,070	1,580	1,500
				3.0~5.0	1,190	1,300	1,450	2,040	490	560	610	760	980	1,070	1,190	1,280	1,800	1,680
			41~50 1mm単位	1.0~2.9	1,210	1,320	1,530	2,260	640	730	800	990	1,160	920	1,090	1,260	1,860	1,770
				3.0~5.0	1,300	1,520	1,730	2,600	720	800	890	1,110	1,300	1,070	1,250	1,420	2,140	2,030
51~60 1mm単位	1.0~2.9	1,460	1,660	1,860	2,490	850	950	1,030	1,130	1,380	1,200	1,370	1,530	2,050	1,950			
	3.0~5.0	1,640	1,850	2,030	2,820	1,000	1,120	1,200	1,230	1,550	1,350	1,520	1,670	2,320	2,210			
				5.1~10.0	1,870	2,080	2,260	3,140	1,070	1,180	1,260	1,370	1,750	1,540	1,710	1,860	2,590	2,530

D≤60...V≤D-2 D≥61...V≤D-4 AWSSに超精密級(公差A)はありません。

Order 注文例: 型式 - T公差選択 - D - V - T  
AWSB - B - D20.0 - V8.0 - T5.0  
AWSS - SB - D20.0 - V8.0 - T5.0

Delivery 出荷日: 3 日目発送

Price 価格: 数量スライド価格 (1円未満切り捨て) P81

数量 1~9 10~19 20~29 30~49 50~100 101以上  
値引率 基準単価 5% 10% 15% 18%

出荷日 通常 +3日

表示数量超過はお見積り



類似寸法は加工部品Cナビガイドブック：P.129

CADデータフォルダ名：35\_Washers

型式	材質 No.	材質	S表面処理	H硬度
並級 T±0.1 精密級 T±0.01				
FWAS	①	SS400	—	—
FWASC	②	S45C	四三酸化鉄皮膜	—
FWASB	③		無電解ニッケルメッキ	—
FWASM	④		低温黒色クロムメッキ	—
FWASR	⑤		アルマイト(白色)	—
FWASA	⑥	A2017	アルマイト(黒色)	—
FWASAB	⑦		—	—
FWASBB	⑧	黄銅(C3604)	—	—
FWASS	⑨	SUS304	—	—
FWASSR	⑩		低温黒色クロムメッキ	—
FWASUS	⑪	SUS316	—	—
FWASCH	⑫	S45C	—	—
FWASBH	⑬		四三酸化鉄皮膜	45~50HRC
FWASMH	⑭		無電解ニッケルメッキ	—
FWASK	⑮		—	—
FWASKB	⑯	SKS3	四三酸化鉄皮膜	55HRC~
FWASKM	⑰		無電解ニッケルメッキ	—
FWASSH	⑱	SUS420J2	—	—
FWASSHR	⑲		低温黒色クロムメッキ	45~50HRC

※S45C焼入タイプは肉厚・長さによって45HRC以下になる場合があります。  
 ※ステンレス焼入タイプ(FWASSH・FWASSHR)は、焼入により変色する場合があります。

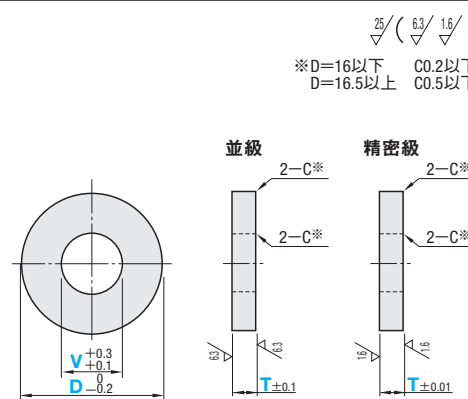

型式	D	V指定 0.5mm単位 (V寸以上)	T指定 0.1mm単位	¥基準単価																				
				①	②	③	④	⑤	⑥	⑦	⑧	⑨	⑩	⑪	⑫	⑬	⑭	⑮	⑯	⑰	⑱			
FWS FWSSC FWSSB FWSSM FWSSR FWSSA FWSSAB FWSSB FWSSR FWSSS FWSSCH FWSSBH FWSSMH FWSSK FWSSKB FWSSKM FWSSSH FWSSHR	4.0~10.0 0.5mm単位	1.0~2.0	2.0	150	170	190	190	240	210	280	240	280	340	340	210	230	230	250	280	280	340	400		
				190	200	240	240	280	250	330	280	330	380	400	260	280	280	310	330	340	400	460	460	
				240	270	310	310	350	320	450	430	450	510	550	350	360	360	420	440	460	520	530	530	620
	10.5~20.0 0.5mm単位	1.0~2.0	2.0	2.0	250	270	330	340	330	350	430	390	430	490	510	360	380	420	440	460	520	530	530	
					260	280	340	360	340	380	470	430	470	530	540	370	400	430	450	490	530	570	560	560
					320	350	420	450	400	460	590	540	590	650	690	480	510	530	580	610	660	750	730	730
	21~30 1mm単位	1.0~2.0	2.0	2.0	300	340	380	380	390	390	490	440	490	550	630	420	450	460	570	600	630	610	600	
					320	350	410	420	400	430	550	490	550	600	690	470	490	500	600	660	690	680	670	670
					400	420	500	510	480	510	690	610	690	750	900	570	610	620	780	820	850	880	850	850
	31~40 1mm単位	1.0~2.0	2.0	2.0	360	380	460	490	490	500	620	560	620	740	—	500	540	590	690	730	820	770	790	
					430	450	540	580	560	600	740	650	740	850	—	620	650	700	840	880	960	900	910	910
					510	540	640	670	640	700	870	780	870	980	—	720	760	810	980	1,030	1,120	1,130	1,120	1,120
	41~50 1mm単位	1.0~2.0	2.6	2.0	560	590	710	770	810	790	970	880	970	1,150	—	810	850	920	1,090	1,150	1,280	1,130	1,250	
					630	660	790	840	880	880	1,080	980	1,080	1,270	—	890	940	1,020	1,210	1,280	1,410	1,300	1,410	1,410
					700	740	880	940	960	980	1,200	1,080	1,200	1,390	—	990	1,060	1,130	1,350	1,430	1,570	1,500	1,600	1,600
	51~60 1mm単位	1.0~2.0	3.0	2.0	680	710	840	890	980	960	1,090	990	1,090	1,330	—	910	960	1,030	1,390	1,470	1,600	1,200	1,370	
					800	830	980	1,040	1,110	1,100	1,190	1,080	1,190	1,440	—	990	1,050	1,110	1,510	1,590	1,740	1,360	1,520	1,520
					860	880	1,040	1,090	1,170	1,180	1,350	1,210	1,350	1,590	—	1,100	1,160	1,230	1,690	1,780	1,930	1,540	1,690	1,690
	61~80 1mm単位	5.0~10.0	90.0	2.0	1,180	1,190	1,400	1,480	1,830	1,760	1,410	1,380	1,410	2,300	—	1,490	1,570	1,660	2,490	2,630	2,840	2,070	2,560	
1,450					1,460	1,720	1,800	2,370	2,220	2,220	1,730	2,220	2,960	—	1,820	1,920	2,030	3,040	3,210	3,470	2,530	3,270	3,270	3,270
81~100 1mm単位	5.0~10.0	90.0	2.0	1,450	1,460	1,720	1,800	2,370	2,220	2,220	1,730	2,220	2,960	—	1,820	1,920	2,030	3,040	3,210	3,470	2,530	3,270		

Order 注文例: 型式 - D - V - T  
FWSSC - D71 - V50.0 - T10.0

Delivery 出荷日: 3 日目発送 (在庫A 200円/1本) P82

Alteration 追加加工: 右ページ

Price 価格: 数量スライド価格 (1円未満切り捨て) P81

数量	1~19	20~49	50~99	100~199	200~300	301以上
値引率	—	5%	10%	15%	18%	出荷日・価格
出荷日	通常	通常	通常	通常	+3日	共にお見積

※301以上お見積りになります。

型式	D	V指定 0.5mm単位 (V寸以上)	T指定 0.1mm単位	¥基準単価																			
				①	②	③	④	⑤	⑥	⑦	⑧	⑨	⑩	⑪	⑫	⑬	⑭	⑮	⑯	⑰	⑱		
FWAS FWASC FWASB FWASM FWASR FWASA FWASAB FWASBB FWASS FWASSR FWASUS FWASCH FWASBH FWASMH FWASK FWASKB FWASKM FWASSH FWASSHR	4.0~10.0 0.5mm単位	1.0~2.0	2.0	280	310	340	340	350	380	520	520	720	380	390	390	520	540	540	510	510			
				330	360	370	370	390	380	620	610	720	450	470	460	620	640	640	600	600	600	600	
				450	450	460	460	480	510	830	790	960	590	610	610	820	840	840	810	810	810	810	
	10.5~20.0 0.5mm単位	1.0~2.0	2.0	2.0	420	440	500	520	530	560	810	780	1,010	570	620	640	800	850	880	780	780		
					440	460	530	560	570	590	870	830	1,010	620	650	680	850	900	940	840	840	840	840
					580	600	670	690	700	720	1,110	1,050	1,300	790	820	850	1,090	1,140	1,180	1,070	1,070	1,070	1,070
	21~30 1mm単位	1.0~2.0	2.0	2.0	530	550	650	650	650	660	710	1,020	960	1,010	1,250	890	800	1,000	1,090	1,110	990	990	
					580	610	710	720	730	760	1,150	1,080	1,330	810	870	880	1,120	1,210	1,220	1,110	1,110	1,110	1,110
					750	770	890	900	910	800	1,450	1,360	1,690	1,030	1,070	1,100	1,430	1,500	1,530	1,410	1,410	1,410	1,410
	31~40 1mm単位	1.0~2.0	2.0	2.0	650	680	800	800	910	890	910	1,260	1,240	—	900	970	1,010	1,250	1,340	1,400	1,230	1,230	
					800	820	950	990	1,000	960	1,550	1,500	—	1,090	1,160	1,210	1,520	1,620	1,680	1,500	1,500	1,500	1,500
					960	990	1,120	1,160	1,180	990	1,850	1,770	—	1,310	1,390	1,430	1,820	1,930	1,990	1,790	1,790	1,790	1,790
	41~50 1mm単位	1.0~2.0	2.6	2.0	750	770	970	1,040	1,050	1,220	1,720	1,710	—	1,160	1,310	1,380	1,620	1,820	1,920	1,660	1,660		
					870	910	1,110	1,170	1,180	1,270	1,970	1,930	—	1,340	1,490	1,560	1,870	2,070	2,160	1,900	1,900	1,900	1,900
					1,030	1,070	1,280	1,340	1,350	1,320	2,280	2,210	—	1,570	1,710	1,770	2,180	2,380	2,460	2,200	2,200	2,200	2,200
	51~60 1mm単位	1.0~2.0	3.0	2.0	880	900	1,080	1,140	1,210	1,440	1,680	1,740	—	1,180	1,310	1,370	1,840	2,050	2,140	1,620	1,620		
					1,000	1,010	1,200	1,260	1,310	1,490	1,900	1,930	—	1,340	1,460	1,530	2,090	2,300	2,390	1,830	1,830	1,830	1,830
					1,140	1,150	1,350	1,410	1,490	1,530	2,190	2,190	—	1,540	1,660	1,720	2,400	2,610	2,690	2,100	2,100	2,100	2,100
	61~80 1mm単位	5.0~10.0	90.0	2.0	1,540	1,560	1,830	1,910	2,180	—	—	—	—	—	2,070	2,250	2,330	—	—	—	—	—	
1,880					1,910	2,230	2,330	2,820	—	—	—	—	—	—	—	—	—	—	—	—	—	—	—
81~100 1mm単位	5.0~10.0	90.0	2.0	1,880	1,910	2,230	2,330	2,820	—	—	—	—	—	—	—	—	—	—	—	—	—	—	

◎D・V加工条件 D≤60 → V≤D-2 材質SKS3・A2017のD・V 4≤D≤10 → V≤D-2 10.5≤D≤30 → V≤D-4 材質A2017・SUS316 → T≥2  
 D≥61 → V≤D-4 加工条件は右記になります。 31≤D≤60 → V≤D-6 61 ≤D≤80 → V≤D-8 81 ≤D≤100 → V≤D-10 価格表記の無いサイズは規格にありません。

Order 注文例: 型式 - D - V - T (KC・SC・WSC・VKC・DKC・HKC)  
FWASS - D20 - V10 - T5 - VKC

Delivery 出荷日: 3 日目発送 (在庫A 200円/1本) P82

Alteration 追加加工: 右ページ

Price 価格: 数量スライド価格 (1円未満切り捨て) P81

数量	1~19	20~49	50~99	100~199	200~300	301以上
値引率	—	5%	10%	15%	18%	出荷日・価格
出荷日	通常	通常	通常	通常	+3日	共にお見積

※301以上お見積りになります。

Alterations	Code	Spec.	¥/1Code	Alterations	Code	Spec.	¥/1Code
キー溝逃げ加工	KC	キー溝逃げ加工をします。 [指定方法] KC 加工条件 ◎V≥8 ◎D61~100不可	300	内径公差変更	VKC	内径の公差をH7に変更します。 [指定方法] VKC 加工条件 ◎D≥6 V≥3	300
一面カット	SC	一面カットをします。 [指定方法] SC10 SC=指定1mm単位 SC≥V/2+2 ◎D4~8不可	200	外径公差変更	DKC (g6) HKC (h7)	外径の公差をg6もしくはh7に変更します。 [指定方法] DKC・HKC 加工条件 ◎D≥43のときT≥1.5 ◎D≥6	300
二面カット	WSC	二面カットをします。 [指定方法] WSC10 WSC=指定1mm単位 WSC≥V+4 ◎D4~8不可	400				

35 ワッシャ カラー・シム

# 金属ワッシャ

一並級/精密級 内外径公差選択・寸法フリー指定タイプ



類似寸法は加工部品Cナビガイドブック：P.129

CADデータフォルダ名：35\_Washers

**RoHS**

型式	材質	S表面処理
並級 精密級	S45C	四三酸化鉄皮膜 無電解ニッケルメッキ
SWSC SWMC		
SWSB SWMB		
SWSM SWMM		
SWSS SWMS	SUS304	—

D	D公差選択			
	G	H	N	X
5.0~8.5	—	—	—	—
9.0~10.0	-0.005	0	—	—
	-0.014	-0.015		
10.5~18.0	-0.006	0	—	—
	-0.017	-0.018		
18.5~30	-0.007	0	-0.1	0
	-0.020	-0.021	-0.3	-0.2
31~50	-0.009	0	—	—
	-0.025	-0.025		
51~60	-0.010	0	—	—
	-0.029	-0.030		

V	V公差選択			
	H	N	X	
3.0	+0.010	—	—	—
3.5~6.0	0	—	—	—
	+0.012			
6.5~10.0	0	—	—	—
	+0.015			
10.5~18.0	+0.018	+0.3	+0.1	+0.2
	0			
18.5~30.0	+0.021	—	—	—
	0			
30.5~50.0	+0.025	—	—	—
	0			
50.5~58.0	+0.030	—	—	—
	0			

内外径公差価格番号表  
D(外径) V(内径) 価格番号  
G H N X  
① ② ③

価格表の見方  
<例>材質S45C、外径g6、内径H7、厚み公差±0.01を注文する場合  
型式：SWMC—GH—D10.0—V4.0—T1.0

1.内外径公差価格番号表を確認します。(GHは価格番号②)  
2.精密級の価格表から、内外径公差価格番号②の欄を参照します。  
3.D・T寸法より価格1,020円

並級 精密級

※D=16以下 C0.2以下  
D=16.5以上 C0.5以下

型式	D公差選択	V公差選択	D	V 指定0.5mm単位	T 指定0.1mm単位	¥基準単価											
						SWSC			SWSB			SWSM			SWSS		
						公差①	公差②	公差③	公差①	公差②	公差③	公差①	公差②	公差③	公差①	公差②	公差③
SWSC SWSB SWSM SWSS	G H N X	H N X	5.0~10.0 0.5mm単位	3.0~58.0 (V≤D-2) 下記参照	1.0~2.9	400	750	180	410	760	180	420	760	210	—	—	—
					3.0~5.0	440	780	210	450	790	230	450	790	250	510	880	310
					5.1~10.0	490	830	280	500	860	290	520	850	330	610	970	430
					1.0~2.9	500	860	290	560	880	310	540	880	360	—	—	—
					3.0~5.0	510	870	300	560	890	320	550	890	380	620	990	450
					5.1~10.0	560	930	380	630	960	400	620	960	470	780	1,080	570
			10.5~20.0 0.5mm単位	1.0~2.9	560	930	380	630	960	400	590	960	410	—	—	—	
				3.0~5.0	590	960	410	670	980	440	620	990	450	790	1,090	580	
				5.1~10.0	730	1,040	510	750	1,060	540	700	1,070	550	910	1,210	730	
				1.0~2.9	630	1,000	460	710	1,020	490	690	1,020	530	—	—	—	
				3.0~5.0	750	1,060	540	790	1,090	580	760	1,130	630	960	1,240	780	
				5.1~10.0	840	1,140	640	870	1,170	680	840	1,200	730	1,080	1,360	930	
21~30 1mm単位	1.0~2.9	900	1,190	720	940	1,240	760	960	1,250	780	—	—	—				
	3.0~5.0	970	1,260	800	1,010	1,300	840	1,020	1,310	860	1,280	1,550	1,160				
	5.1~10.0	1,050	1,340	890	1,090	1,370	940	1,110	1,390	960	1,390	1,650	1,290				
	1.0~2.9	1,100	1,380	950	1,150	1,420	1,010	1,110	1,470	1,070	—	—	—				
	3.0~5.0	1,240	1,520	1,120	1,300	1,560	1,180	1,250	1,620	1,260	1,520	1,760	1,440				
	5.1~10.0	1,300	1,570	1,190	1,360	1,620	1,260	1,410	1,670	1,320	1,670	1,910	1,620				

D・V公差にGまたはHを選択した場合は、D≥9の適用となります。またその場合、V・Tの指定範囲は下表となります。

D	V	T
9~30	D-V≥6	1~10
31~60	D-V≥12	2~10

価格表記の無いサイズは規格にありません。

Order注文例 型式 - 公差選択 - D - V - T

Price価格 数量スライド価格 (1円未満切り捨て) P81

数量	1~9	10~19	20~29	30~49	50~100	101以上
値引率	—	5%	10%	15%	18%	出荷日・価格 共に見積
出荷日	—	通常	—	—	—	+3日

101円以上お見積りになります。

Delivery出荷日 3 日目発送 ストック A 200円/1本 大口出荷日 +3 日目出荷 数量 50~100

Alteration追加加工 型式 - 公差選択 - D - V - T - (TCB・TCC・TCD・TCE) 右ページ

型式	D公差選択	V公差選択	D	V 指定0.5mm単位	T 指定0.1mm単位	¥基準単価											
						SWMC			SWMB			SWMM			SWMS		
						公差①	公差②	公差③	公差①	公差②	公差③	公差①	公差②	公差③	公差①	公差②	公差③
SWMC SWMB SWMS	G H N X	H N X	5.0~10.0 0.5mm単位	3.0~58.0 (V≤D-2) 下記参照	1.0~2.9	600	1,020	300	610	1,030	310	610	1,030	310	—	—	—
					3.0~5.0	650	1,070	360	670	1,080	350	670	1,080	350	880	1,290	580
					5.1~10.0	770	1,180	450	780	1,200	450	780	1,200	460	1,070	1,490	780
					1.0~2.9	760	1,170	440	790	1,210	460	810	1,240	500	—	—	—
					3.0~5.0	780	1,200	450	820	1,250	500	850	1,260	530	1,100	1,530	810
					5.1~10.0	920	1,350	600	960	1,370	630	980	1,400	660	1,330	1,750	1,050
			10.5~20.0 0.5mm単位	1.0~2.9	870	1,290	540	930	1,350	610	940	1,350	620	—	—	—	
				3.0~5.0	930	1,350	610	990	1,420	670	1,000	1,430	690	1,360	1,780	1,080	
				5.1~10.0	1,100	1,530	770	1,170	1,590	840	1,170	1,600	860	1,640	2,070	1,370	
				1.0~2.9	1,000	1,430	680	1,080	1,500	750	1,190	1,620	880	—	—	—	
				3.0~5.0	1,160	1,570	820	1,230	1,650	900	1,290	1,710	980	1,730	2,150	1,460	
				5.1~10.0	1,330	1,750	990	1,390	1,810	1,060	1,440	1,850	1,120	2,010	2,430	1,750	
21~30 1mm単位	1.0~2.9	1,140	1,550	770	1,250	1,660	910	1,310	1,730	990	—	—	—				
	3.0~5.0	1,240	1,650	900	1,380	1,800	1,050	1,440	1,860	1,130	2,110	2,530	1,860				
	5.1~10.0	1,400	1,820	1,070	1,550	1,970	1,210	1,610	2,030	1,290	2,400	2,820	2,160				
	1.0~2.9	1,350	1,760	900	1,480	1,900	1,020	1,550	1,970	1,240	—	—	—				
	3.0~5.0	1,530	1,950	1,010	1,660	2,080	1,130	1,740	2,160	1,430	2,270	2,690	1,960				
	5.1~10.0	1,640	2,060	1,160	1,780	2,200	1,270	1,850	2,260	1,530	2,560	2,970	2,250				

D・V公差にGまたはHを選択した場合は、D≥9の適用となります。またその場合、V・Tの指定範囲は下表となります。

D	V	T
9~30	D-V≥6	1~10
31~60	D-V≥12	2~10

価格表記の無いサイズは規格にありません。

Order注文例 型式 - 公差選択 - D - V - T

Price価格 数量スライド価格 (1円未満切り捨て) P81

数量	1~9	10~19	20~29	30~49	50~100	101以上
値引率	—	5%	10%	15%	18%	出荷日・価格 共に見積
出荷日	—	通常	—	—	—	+3日

101円以上お見積りになります。

Delivery出荷日 3 日目発送 ストック A 200円/1本 大口出荷日 +3 日目出荷 数量 50~100

Alteration追加加工 型式 - 公差選択 - D - V - T - (TSB・TSC・TSD・TSE) 右ページ

並級 T 公差変更	Alterations Code	マイナス公差変更	プラス公差変更	ゼロ・マイナス公差変更	ゼロ・プラス公差変更
	Code	TCB	TCC	TCD	TCE
<p>並級に適用</p>	<p>並級に適用</p>	厚み公差(T)を変更 T -0.1 T -0.3 [指定方法] TCB	厚み公差(T)を変更 T +0.3 T +0.1 [指定方法] TCC	厚み公差(T)を変更 T 0 T -0.2 [指定方法] TCD	厚み公差(T)を変更 T +0.2 T 0 [指定方法] TCE
¥/1Code	80	80	80	80	

精密級 T 公差変更	Alterations Code	マイナス公差変更	プラス公差変更	ゼロ・マイナス公差変更	ゼロ・プラス公差変更
	Code	TSB	TSC	TSD	TSE
<p>精密級に適用</p>	<p>精密級に適用</p>	厚み公差(T)を変更 T -0.01 T -0.03 [指定方法] TSB	厚み公差(T)を変更 T +0.03 T +0.01 [指定方法] TSC	厚み公差(T)を変更 T 0 T -0.02 [指定方法] TSD	厚み公差(T)を変更 T +0.02 T 0 [指定方法] TSE
¥/1Code	100	100	100	100	

35 カラー・シム ワッシャ





WASHERS WITH FEMALE SCREW

# 金属ワッシャ

—タップタイプ—



ステンレス・めっき品  
脱脂洗浄サービス  
対応商品詳細は下記URLへ  
<http://fa.misumi.jp>

◎類似寸法は加工部品Cナビガイドブック：P.130  
◎CADデータフォルダ名：35\_Washers



T寸選択タイプ	T寸指定タイプ	寸法フリー指定タイプ	並目	並目	並目	材質	S表面処理
—	—	FWTAC	—	—	—	S45C	—
WTAB	TWTAB	FWTAB	—	—	—	S45C	四三酸化鉄皮膜
WTAM	TWTAM	FWTAM	—	—	—	黄銅(C3604)	無電解ニッケルメッキ
WTBB	TWTBB	FWTBB	—	—	—	黄銅(C3604)	—
—	—	FWTAA	—	—	—	A2017	アルマイト(白色)
—	—	FWTAAAB	—	—	—	A2017	アルマイト(黒色)
WTAS	TWTAS	FWTAS	—	—	—	SUS304	—

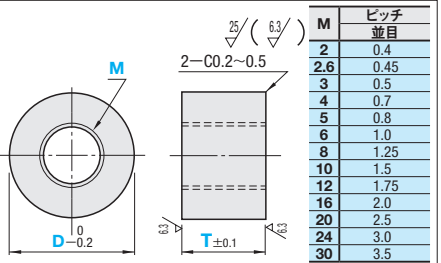

### T寸選択タイプ

型式 Type	D	M 選択					T 選択					¥基準単価			
		2	3	4	5	6	3	5	8	10	15	WTAB	WTAM	WTBB	WTAS
WTAB WTAM WTBB WTAS	10	2	3	4	5	6	3	5	8	10	15	120	140	310	150
	12	4	5	6	8	10	5	8	10	15	20	130	160	350	170
	16	5	6	8	10	12	5	8	10	15	20	150	180	370	200
	20	6	8	10	12	16	8	10	15	20	25	200	230	430	240
	30	8	10	12	16	20	10	15	20	25	30	290	350	690	380
	40	10	12	16	20	25	15	20	25	30	35	390	510	860	550
50	12	16	20	25	30	15	20	25	30	35	550	720	1,240	830	
60	16	20	25	30	35	15	20	25	30	35	750	950	1,600	1,060	

### T寸指定タイプ

型式 Type	D	M 選択					T 指定0.5mm単位	型式 Type	D	T 指定0.5mm単位	¥基準単価			
		2	3	4	5	6					TWTAB	TWTAM	TWTBB	TWTAS
TWTAB TWTAM TWTBB TWTAS	6	2	3	4	5	6	6~10	6~10	3.0~5.0	240	260	370	300	
	8	2	3	4	5	6			5.5~10.0	250	280	390	320	
	10	2	3	4	5	6			10.5~20.0	280	300	440	330	
	12	4	5	6	8	10			3.5~5.0	250	280	390	320	
	16	5	6	8	10	12			5.5~10.0	350	370	490	420	
	20	6	8	10	12	16			10.5~20.0	400	440	570	480	
30	8	10	12	16	20	10.5~20.0	300	330	500	370				
40	10	12	16	20	25	20~30	5.5~10.0	480	530	700	590			
50	12	16	20	25	30	20~30	10.5~20.0	580	630	890	720			

### 寸法フリー指定タイプ

型式	D	M 選択	T 指定0.5mm単位	¥基準単価						
				FWTAC	FWTAB	FWTAM	FWTAA	FWTBB	FWTAAAB	FWTAS
6~10 (0.5mm単位)			3.0~5.0	350	380	400	410	460	420	
				5.5~10.0	360	400	430	430	490	440
				10.5~20.0	400	440	450	440	520	460
				20.5~30.0	430	450	470	460	550	490
				30.5~40.0	720	810	890	840	1,000	960
				40.5~50.0	900	1,010	1,080	1,040	1,230	1,220
				5.5~10.0	360	400	430	430	490	440
				10.5~20.0	500	540	570	570	660	590
				20.5~30.0	670	730	780	760	900	800
				30.5~40.0	1,270	1,410	1,470	1,440	1,700	1,710
10.5~20.0 (0.5mm単位)			3.0~5.0	440	480	500	520	590	530	
				5.5~10.0	690	760	790	800	910	810
				10.5~20.0	830	910	960	940	1,100	990
				20.5~30.0	1,010	1,120	1,160	1,140	1,340	1,190
				30.5~40.0	1,630	1,800	1,860	1,810	2,150	2,190
				40.5~50.0	2,030	2,220	2,280	2,250	2,650	2,740
				5.5~10.0	890	1,060	1,230	1,250	1,350	1,270
				10.5~20.0	1,040	1,240	1,430	1,330	1,570	1,460
				20.5~30.0	1,270	1,500	1,740	1,830	1,920	1,800
				30.5~40.0	2,390	2,590	2,660	2,610	3,090	3,150
21~30 (1mm単位)		2 (3≦T≦10)	3.0~5.0	440	480	500	520	590	530	
				5.5~10.0	690	760	790	800	910	810
				10.5~20.0	830	910	960	940	1,100	990
				20.5~30.0	1,010	1,120	1,160	1,140	1,340	1,190
				30.5~40.0	1,630	1,800	1,860	1,810	2,150	2,190
				40.5~50.0	2,030	2,220	2,280	2,250	2,650	2,740
				5.5~10.0	890	1,060	1,230	1,250	1,350	1,270
				10.5~20.0	1,040	1,240	1,430	1,330	1,570	1,460
				20.5~30.0	1,270	1,500	1,740	1,830	1,920	1,800
				30.5~40.0	2,390	2,590	2,660	2,610	3,090	3,150
31~40 (1mm単位)		2.6 (3≦T≦13)	3.0~5.0	440	480	500	520	590	530	
				5.5~10.0	690	760	790	800	910	810
				10.5~20.0	830	910	960	940	1,100	990
				20.5~30.0	1,010	1,120	1,160	1,140	1,340	1,190
				30.5~40.0	1,630	1,800	1,860	1,810	2,150	2,190
				40.5~50.0	2,030	2,220	2,280	2,250	2,650	2,740
				5.5~10.0	890	1,060	1,230	1,250	1,350	1,270
				10.5~20.0	1,040	1,240	1,430	1,330	1,570	1,460
				20.5~30.0	1,270	1,500	1,740	1,830	1,920	1,800
				30.5~40.0	2,390	2,590	2,660	2,610	3,090	3,150
41~50 (1mm単位)		3 (3≦T≦48)	3.0~5.0	440	480	500	520	590	530	
				5.5~10.0	690	760	790	800	910	810
				10.5~20.0	830	910	960	940	1,100	990
				20.5~30.0	1,010	1,120	1,160	1,140	1,340	1,190
				30.5~40.0	1,630	1,800	1,860	1,810	2,150	2,190
				40.5~50.0	2,030	2,220	2,280	2,250	2,650	2,740
				5.5~10.0	890	1,060	1,230	1,250	1,350	1,270
				10.5~20.0	1,040	1,240	1,430	1,330	1,570	1,460
				20.5~30.0	1,270	1,500	1,740	1,830	1,920	1,800
				30.5~40.0	2,390	2,590	2,660	2,610	3,090	3,150
51~60 (1mm単位)		4 (4≦T≦50)	3.0~5.0	440	480	500	520	590	530	
				5.5~10.0	690	760	790	800	910	810
				10.5~20.0	830	910	960	940	1,100	990
				20.5~30.0	1,010	1,120	1,160	1,140	1,340	1,190
				30.5~40.0	1,630	1,800	1,860	1,810	2,150	2,190
				40.5~50.0	2,030	2,220	2,280	2,250	2,650	2,740
				5.5~10.0	890	1,060	1,230	1,250	1,350	1,270
				10.5~20.0	1,040	1,240	1,430	1,330	1,570	1,460
				20.5~30.0	1,270	1,500	1,740	1,830	1,920	1,800
				30.5~40.0	2,390	2,590	2,660	2,610	3,090	3,150
61~80 (1mm単位)		8 (8≦T≦50)	3.0~5.0	440	480	500	520	590	530	
				5.5~10.0	690	760	790	800	910	810
				10.5~20.0	830	910	960	940	1,100	990
				20.5~30.0	1,010	1,120	1,160	1,140	1,340	1,190
				30.5~40.0	1,630	1,800	1,860	1,810	2,150	2,190
				40.5~50.0	2,030	2,220	2,280	2,250	2,650	2,740
				5.5~10.0	890	1,060	1,230	1,250	1,350	1,270
				10.5~20.0	1,040	1,240	1,430	1,330	1,570	1,460
				20.5~30.0	1,270	1,500	1,740	1,830	1,920	1,800
				30.5~40.0	2,390	2,590	2,660	2,610	3,090	3,150
81~100 (1mm単位)		24 (10≦T≦50)	3.0~5.0	440	480	500	520	590	530	
				5.5~10.0	690	760	790	800	910	810
				10.5~20.0	830	910	960	940	1,100	990
				20.5~30.0	1,010	1,120	1,160	1,140	1,340	1,190
				30.5~40.0	1,630	1,800	1,860	1,810	2,150	2,190
				40.5~50.0	2,030	2,220	2,280	2,250	2,650	2,740
				5.5~10.0	890	1,060	1,230	1,250	1,350	1,270
				10.5~20.0	1,040	1,240	1,430	1,330	1,570	1,460
				20.5~30.0	1,270	1,500	1,740	1,830	1,920	1,800
				30.5~40.0	2,390	2,590	2,660	2,610	3,090	3,150

Order 注文例

型式 - D - M - T

WTAB12 - 6 - 5

TWTAB12 - 6 - 5.5

FWTAM - D20 - M5 - T4.5

Delivery 出荷日

3 日目発送

ストーク T 400円/1本

ストーク A 200円/1本

◎同一サイズ3本以上は一律540円 (ストークTは除く)

T寸選択タイプ

3 日目発送

ストーク A 200円/1本

◎同一サイズ3本以上は一律540円

T寸指定・寸法フリー指定タイプ 材質 S45C・SUS304

3 日目発送

ストーク A 200円/1本

◎同一サイズ3本以上は一律540円

寸法フリー指定タイプ 材質 A2017

5 日目発送

ストーク B 200円/1本

◎同一サイズ3本以上は一律540円

数量スライド価格 (1円未満切り捨て) P.81

数量	1~19	20~49	50~99	100~199	200~300	301以上
値引率	標準	5%	10%	15%	18%	出荷日・価格
出荷日	通常					+3日

◎301円以上お見積りになります。

Price 価格

Alteration 追加加工

型式 - D - M - T - (WSC)

FWTAS - D15 - M6 - T15 - WSC10

Alteration Code Spec. ¥/1Code

WSC 二面カットをします。  
[指定方法] WSC10  
WSC=指定1mm単位  
WSC≧M+4  
◎D6~D8不可  
◎寸選択タイプ・T寸指定タイプ適用不可

400

◎(D-M)/2≧2 ◎T≦M×8 ◎M2・M2.6 …… T≦M×5  
◎材質：黄銅の場合 4≦D≦10 …… V≦D-2 10.5≦D≦30 …… V≦D-4  
31≦D≦60 …… V≦D-6 61≦D≦80 …… V≦D-8  
81≦D≦100 …… V≦D-10



WASHERS-SHOULDER TYPE-

# 金属ワッシャ

—ツバ付タイプ—



ステンレス・めっき品  
脱脂洗浄サービス  
対応商品詳細は下記URLへ  
<http://fa.misumi.jp>

◎類似寸法は加工部品Cナビガイドブック：P.132  
◎CADデータフォルダ名：35\_Washers

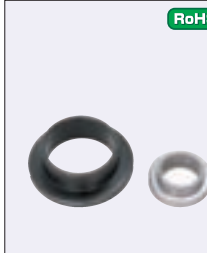

型式	並級	精密級	材質	S表面処理	H硬度
FTCC	FTCMC	—	—	—	—
FTCB	FTCMB	—	S45C	四三酸化鉄皮膜	—
FTCM	FTCMM	—	黄銅(C3604)	無電解ニッケルメッキ	—
FTCBB	—	—	—	—	—
FTCSK	—	—	SKS3	四三酸化鉄皮膜	55HRC~

# 金属ワッシャ

—ザグリ穴タイプ—



類似寸法は加工部品Cナビガイドブック：P.130

CADデータフォルダ名：35\_Washers

並級	T寸公差±0.1		精密級		材質	S表面処理	H硬度
	T寸選択タイプ	寸法フリー指定タイプ	T寸選択タイプ	寸法フリー指定タイプ			
—	—	FWZASS	—	—	SS400	—	—
—	—	FWZAC	—	FWZSC	S45C	四三酸化鉄皮膜 無電解ニッケルメッキ	—
WZAB	TWZAB	FWZAB	TWZSB	FWZSB			
WZAM	TWZAM	FWZAM	TWZSM	FWZSM			
—	—	FWZAA	—	—	A2017	アルマイト(白色)	—
—	—	FWZAAB	—	—	A2017	アルマイト(黒色)	—
WZAS	TWZAS	FWZAS	TWZSS	FWZSS	SUS304	—	—
—	—	FWZACH	—	—	S45C	四三酸化鉄皮膜 無電解ニッケルメッキ	45~50HRC
WZABH	—	FWZABH	—	—			
WZAMH	—	FWZAMH	—	—			
—	—	FWZASKB	—	—	SKS3	四三酸化鉄皮膜 無電解ニッケルメッキ	55HRC~
—	—	FWZASKM	—	—			
—	—	FWZASK	—	—			
WZASH	—	FWZASH	—	—	SUS420J2	—	45~50HRC

※S45C焼入タイプは肉厚・長さによっては45HRC以下になる場合があります。 ※ステンレス焼入タイプ(WZASH・FWZASH)は焼入により変色する場合があります。

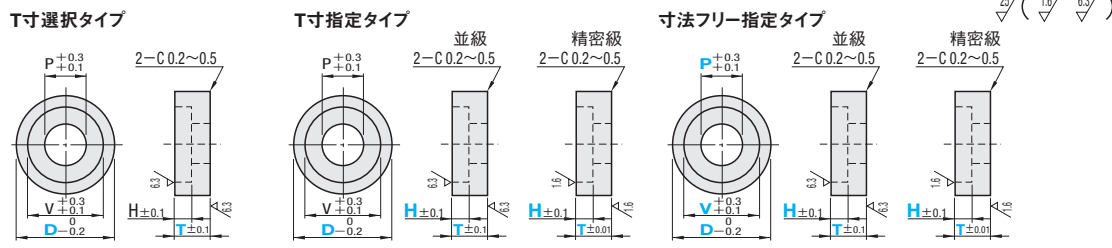

### T寸選択タイプ

型式	D	H	T 選択			V	P	¥基準単価											
			6	8	10			WZAB	WZAM	WZAS	WZABH	WZAMH	WZASH						
WZAB WZAM WZABH WZAMH WZASH	10	4	6	8	10	6	3.5	100	120	130	110	140	170						
	12	5	8	10		8	4.5	120	140	150	130	170	180						
	14	6	8	10		10	5.5	130	160	180	140	190	210						
	15	8		10	12			140	180	190	170	210	230						
	20	8		10	12	15		180	230	240	210	260	360						
	30	10		12	15			270	340	380	330	390	620						
WZSB TWZSM TWZSS	20	12		15	20		370	520	560	450	580	750							
	50	12		15	20	18	500	700	750	600	770	1,120							
	60	12		15	20		640	870	990	750	990	1,430							

### T寸指定タイプ

型式	D	H	T 指定	V	P	¥基準単価					
						並級	精密級	並級	精密級	並級	精密級
—並級— TWZAB TWZAM TWZAS	10~20	1.0~18.0	3.0~5.0	6	3.5	420	440	530	540	560	640
			5.5~10.0	8	4.5	420	440	530	540	560	640
			10.5~20.0	10	5.5	600	640	780	740	780	870
—精密級— TWZSB TWZSM TWZSS	30	3.0~20.0 (H+2≦T≦P×8)	3.0~5.0	11	6.5	500	540	640	630	670	760
			5.5~10.0	11	6.5	500	540	640	630	670	760
			10.5~20.0	14	9	860	930	1,120	1,010	1,080	1,200

### 数量スライド価格

数量	1~19	20~49	50~99	100~199	200~300	301以上
値引率		5%	10%	15%	18%	出荷日・価格 共にお見積
出荷日		通常	通常	通常	通常	+3日

※301以上お見積りになります。

### Price 価格

Order 注文例

型式 - T

WZAS15 - 10

### T寸指定タイプ

型式 - H - T

TWZAB10 - 3.5 - 10.0

### Delivery 出荷日

3 日目発送

ストーク T 400円/1本

ストーク A 200円/1本

※P82

※同一サイズ3本以上は一律540円(ストークTは除く)

大口 出荷日 +3 日目出荷

数量 200~300

※ストーク対応なし

### T寸指定タイプ

3 日目発送

ストーク A 200円/1本

※P82

※同一サイズ3本以上は一律540円

### 寸法フリー指定タイプ

型式	D	指定0.5mm単位				¥基準単価																			
		V	P	H	T	並級																			
						FWZASS	FWZAC	FWZAB	FWZAM	FWZAA	FWZASKB	FWZASKM	FWZASK	FWZACH	FWZABH	FWZAMH	FWZASKB	FWZASKMB	FWZAS	FWZSC	FWZSB	FWZSM	FWZSS		
—並級— FWZASS FWZAC FWZAB FWZAM FWZAA FWZASKB FWZASKM FWZASK FWZACH FWZABH FWZAMH FWZASKB FWZASKMB FWZAS	10.0~20.0 (0.5mm単位)	50~90.0	3.0~88.0	1.0~48.0	3.0~10.0	400	450	600	630	650	670	600	790	850	750	990	1,060	1,030	570	720	750	860			
					10.5~20.0	580	650	860	920	920	980	800	1,040	1,130	1,000	1,310	1,410	1,480	790	990	1,050	1,170			
					20.5~30.0	690	780	1,030	1,100	1,070	1,170	960	1,250	1,360	1,200	1,510	1,700	1,760	920	1,170	1,240	1,370			
					30.5~40.0	730	820	1,080	1,170	1,120	1,220	1,010	1,320	1,420	1,260	1,650	1,780	1,840	980	1,230	1,310	1,440			
					40.5~50.0	770	870	1,140	1,220	1,180	1,290	1,060	1,390	1,500	1,330	1,740	1,880	1,950	1,080	1,300	1,380	1,540			
					50.5~60.0	480	540	720	780	800	810	710	920	1,000	880	1,150	1,250	1,240	680	840	900	1,020			
—精密級— FWZSB TWZSM TWZSS	81~100 (1mm単位)	50~90.0	3.0~88.0	1.0~48.0	3.0~10.0	820	830	1,350	1,430	1,480	1,500	1,060	1,700	1,810	1,470	2,370	2,520	2,270	1,070	1,610	1,700	1,830			
					10.5~20.0	1,260	1,280	2,070	2,190	2,130	2,310	1,570	2,510	2,670	2,180	3,510	3,730	3,470	1,540	2,370	2,510	2,680			
					20.5~30.0	1,510	1,540	2,480	2,620	2,550	2,770	1,890	3,030	3,220	2,630	4,230	4,490	4,160	1,820	2,810	2,970	3,150			
					30.5~40.0	1,550	1,580	2,540	2,700	2,620	2,840	1,930	3,090	3,290	2,690	4,320	4,590	4,270	1,860	2,880	3,060	3,230			
					40.5~50.0	1,600	1,620	2,610	2,790	2,700	2,920	1,990	3,190	3,390	2,770	4,450	4,740	4,390	1,910	2,960	3,140	3,310			
					50.5~60.0	1,650	1,680	2,700	2,870	2,800	3,010	2,060	3,300	3,510	2,870	4,600	4,890	4,530	1,980	3,060	3,230	3,410			

### 加工条件

D	V	P
10~60のとき	V ≦ D - 2	P ≦ V - 2
61~100のとき	V ≦ D - 4	P ≦ V - 4

2 ≦ (T-H) ≦ P×8 軸径部長さは2mm以上でP×8以下。

### 材質SKS3の加工条件

D	V	P
10のとき	V ≦ D - 2	
10.5~30のとき	V ≦ D - 4	P ≦ V - 2
31~60のとき	V ≦ D - 6	
61~80のとき	V ≦ D - 8	P ≦ V - 4
81~100のとき	V ≦ D - 10	

※価格表記の無いサイズは規格にありません。



Order 注文例  
型式 - D - V - P - H - T  
FWZASS - D25 - V12.0 - P6.0 - H5.5 - T10.5  
FWZSC - D20 - V10.0 - P5.0 - H5.5 - T15.0



●並級  
■数量スライド価格 (※1円未満切り捨て) P81

数量	1~19	20~49	50~99	100~199	200~300	301以上
値引率		5%	10%	15%	18%	出荷日・価格 共にお見積
出荷日		通常	通常	通常	通常	+3日

※301以上お見積りになります。



Delivery 出荷日  
●材質 A2017以外  
3 日目発送  
ストーク A 200円/1本 ※P82

### 精密級

■数量スライド価格 (※1円未満切り捨て) P81

数量	1~19	20~49	50~99
値引率		10%	15%

※表示数量超えはお見積り



Alteration 追加加工  
型式 - D - V - P - H - T - (TKC)  
FWZASH - D15.0 - V10.5 - P6.5 - H12.5 - T18.5 - TKC

Alteration	Code	Spec.	¥/1Code
TKC	T寸公差を変更します。 指定方法TKC T±0.1⇒±0.01 ※FWZAA・FWZAS・FWZASH D61~100のとき不可 ※寸法フリー指定タイプ並級のみ適用(FWZAABは除く)	材質 S45C A2017 SS400	300
		材質 SKS3 SUS420J2	500



# 金属ワッシャ

皿ボルト用タイプ/ボルト穴付タイプ

類似寸法は加工部品Cナビガイドブック：P.130・131

CADデータフォルダ名：35\_Washers

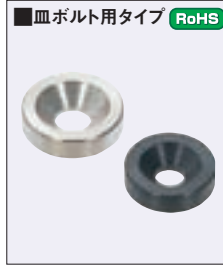

標準タイプ	寸法フリー指定	材質	表面処理
WSRB	FWSRC	S45C	—
WSRM	FWSRB		四三酸化鉄皮膜
WSRS	FWSRM		無電解ニッケルメッキ
—	FWSRA	A2017	アルマイト(白色)
—	FWSRAB		アルマイト(黒色)
WSRS	FWSRS	SUS304	—

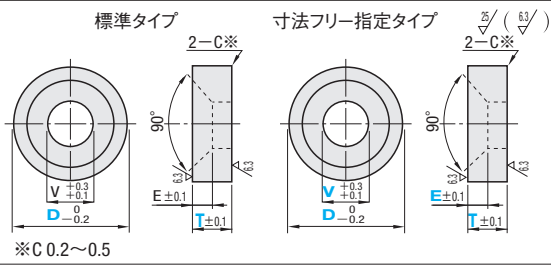

\*C 0.2~0.5

## 皿ボルト用・標準タイプ

型式	D	T	E	V	¥基準単価								
					WSRB	WSRM	WSRS						
14	4	2.5	2.5	4.5	120	130	150						
								3	3	5.5	130	140	160
								5	3.5	6.6	160	180	200
20	4	3.5	6	11	210	250	270						
								5	5	9	190	220	240
25	5	5.5	6	11	290	440	450						
								6	6	11	290	440	450
30	6	6	6	11	360	610	620						
								8	6	11	360	610	620

## 皿ボルト用・寸法フリー指定タイプ

型式	D	V	E	T	¥基準単価					
					FWSRC	FWSRB	FWSRM	FWSRA	FWSRAB	FWSRS
FWSRC FWSRB FWSRM	10.0~20.0 (0.5mm単位)	2.0	2.0~10.0	E≤T	2.0~5.0	420	470	540	590	610
					5.5~10.0	560	640	730	800	810
					21~30 (1mm単位)	520	590	680	730	760
FWSRA FWSRAB FWSRS	31~40 (1mm単位)	2.6	E≤T	2.0~5.0	680	860	910	980	1,010	
				5.5~10.0	1,030	1,170	1,240	1,330	1,370	
				41~50 (1mm単位)	930	1,070	1,210	1,320	1,340	
FWSRA FWSRAB FWSRS	51~60 (1mm単位)	3~30	E≤T	2.0~5.0	1,090	1,250	1,420	1,530	1,580	
				5.5~10.0	970	1,200	1,360	1,480	1,520	
				5.5~10.0	1,130	1,400	1,590	1,720	1,770	

① (D-V)/2-E≥2...最少肉厚は2mm以上必要です。

② E=TのときVの厚みが0になるため真円を保証できません。

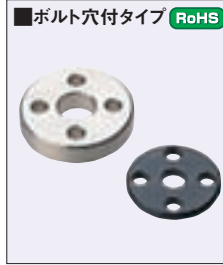

Type	材質	表面処理
WBAC	S45C	—
WBAB		四三酸化鉄皮膜
WBAM		無電解ニッケルメッキ
WBAA	A2017	アルマイト(白色)
WBAAB		アルマイト(黒色)
WBAS	SUS304	—

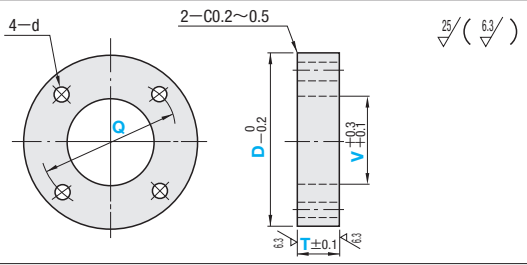

型式	D	V	Q	T	d	通孔ボルト	¥基準単価											
							WBAC	WBAB	WBAM	WBAA	WBAAB	WBAS						
20	3.0~5.0	10.5~13.5	1.0	1.0	3.5	M3	T1~2	T3~5	T6~10	T1~2	T3~5	T6~10	T1~2	T3~5	T6~10	T1~2	T3~5	T6~10
							480	500	560	570	580	650	630	650	730	850	890	1,020
25	3.0~10.0	10.5~17	1.0	1.0	3.5	M3	T1~2	T3~5	T6~10	T1~2	T3~5	T6~10	T1~2	T3~5	T6~10	T1~2	T3~5	T6~10
							510	550	630	610	640	730	650	670	740	870	930	1,110
30	3.0~10.0	12~20	1.0	1.0	4.5	M4	T1~2	T3~5	T6~10	T1~2	T3~5	T6~10	T1~2	T3~5	T6~10	T1~2	T3~5	T6~10
							560	580	680	650	690	780	700	730	830	970	1,030	1,200
35	3.0~16.0	12~25	1.0	1.0	4.5	M4	T1~2	T3~5	T6~10	T1~2	T3~5	T6~10	T1~2	T3~5	T6~10	T1~2	T3~5	T6~10
							620	650	730	730	790	890	810	870	960	1,090	1,210	1,400
40	3.0~20.0	12~30	1.0	1.0	4.5	M4	T1~2	T3~5	T6~10	T1~2	T3~5	T6~10	T1~2	T3~5	T6~10	T1~2	T3~5	T6~10
							710	730	800	810	880	970	900	950	1,040	1,190	1,310	1,490
50	3.0~22.0	14~35	1.0	1.0	5.5	M5	T1~2	T3~5	T6~10	T1~2	T3~5	T6~10	T1~2	T3~5	T6~10	T1~2	T3~5	T6~10
							950	1,020	1,100	1,060	1,130	1,230	1,080	1,160	1,240	1,450	1,600	1,760
60	3.0~28.0	14~40	1.0	1.0	5.5	M5	T1~2	T3~5	T6~10	T1~2	T3~5	T6~10	T1~2	T3~5	T6~10	T1~2	T3~5	T6~10
							1,160	1,300	1,370	1,290	1,450	1,520	1,300	1,470	1,530	1,680	1,830	1,990

① Q≥V+d+4 ② WBAAB・WBAABはT≥2となります。

Order 注文例	型式	D	V	E	Q	T
WSRM14	—	D17.5	V6.5	E3	—	T2.5
FWSRS	—	D17.5	V6.5	E3	—	T7.5
WBA30	—	—	V8	—	Q18	T3

Alterations 追加加工	Code	Spec.	¥/1Code
T寸公差変更	TKC	T寸公差を変更します。 指定方法 TKC T±0.1⇒±0.01 ①皿ボルト用タイプのみ適用	300
止まり穴変更	FC	V穴を止まり穴に変更します。 指定方法 FC3 FC=指定1mm単位 ①T-FC≥2 ②V≥10 ③FC≥2	600

Delivery 出荷日	目録発送	目録発送	目録発送
3	目録発送	目録発送	目録発送
5	目録発送	目録発送	目録発送

Price 価格	数量	1~19	20~49	50~99	100~199
数量	1~19	20~49	50~99	100~199	
値引率	基準単価	5%	10%	15%	

# 金属ワッシャ/長穴ワッシャ

形状選択タイプ フラットタイプ/インロータイプ

類似寸法は加工部品Cナビガイドブック：P.131・132

CADデータフォルダ名：35\_Washers



型式	材質	表面処理
KWSC	S45C	—
KWSB		四三酸化鉄皮膜
KWSM		無電解ニッケルメッキ
KWSS	SUS304	—

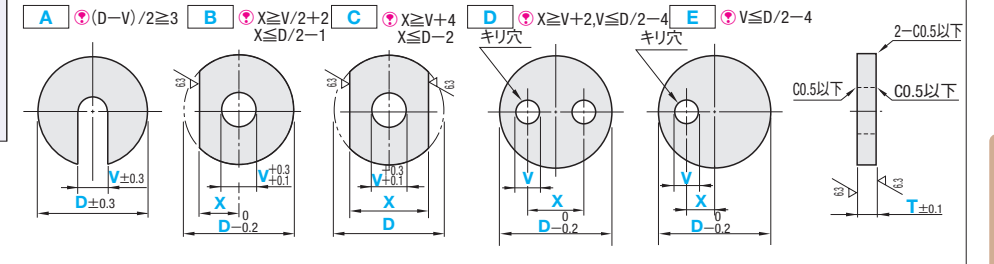

型式	形状選択	D	V	X	T	¥基準単価																																							
						KWSC				KWSB				KWSM				KWSS																											
KWSC KWSB KWSM KWSS	A B C D E	10.0~20.5 0.5mm単位	3~30	4.0~48.0	3.0~10.0	D	T	A	B	C	D	E	A	B	C	D	E	A	B	C	D	E	A	B	C	D	E																		
						10.0	3.0~5.0	900	480	630	1,160	900	920	490	650	1,170	920	1,000	570	740	1,290	1,010	1,070	640	790	1,350	1,080	640	790	1,350	1,080														
20.5	30	5.1~10.0	1,070	540	720	1,220	960	1,080	570	720	1,250	990	1,190	640	800	1,350	1,100	1,280	760	910	1,460	1,190	21	30	3.0~5.0	1,160	580	720	1,260	990	1,170	600	750	1,260	1,010	1,240	660	810	1,360	1,080	1,350	760	910	1,480	1,200
31	40	3.0~5.0	1,470	700	830	1,350	1,100	1,510	720	860	1,400	1,140	1,620	810	950	1,520	1,240	1,740	950	1,090	1,650	1,380	41	40	5.1~10.0	1,660	790	910	1,440	1,190	1,690	810	950	1,470	1,220	1,810	910	1,040	1,600	1,330	1,980	1,100	1,210	1,790	1,520
50	41	5.1~10.0	2,120	1,000	1,120	1,650	1,400	2,150	1,060	1,170	1,680	1,430	2,280	1,130	1,240	1,800	1,520	2,560	1,450	1,530	2,110	1,840																							

Alteration 追加加工	Code	Spec.	¥/1Code
HH	HH	A形状に焼き入れします。 ①硬度45~50HRC ②指定方法 HH ③KWSB・KWSCのみ適用 ④熱処理による変形・歪みが生じる場合があります。	200



Type	材質	表面処理
WLM	S45C	無電解ニッケルメッキ
WLS	SUS304	—

Type	材質	表面処理
WLHM	S45C	無電解ニッケルメッキ
WLHS	SUS304	—

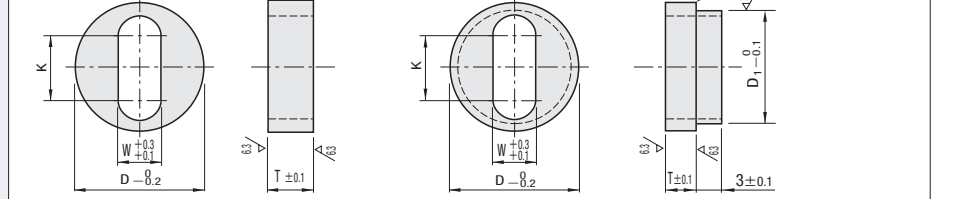

## フラットタイプ

型式	No.	D	T	K	W	適用ボルト	¥基準単価	
							WLM	WLS
WLM WLS	3	18	5	3.5	M3	200	240	
	4	20	6	4.5	M4	200	250	
	5	22	7	5.5	M5	240	290	
	6	26	8	6.6	M6	290	350	
	8	30	10	9	M8	340	410	
	10	38	12	11	M10	650	740	
	12	46	16	14	M12	730	820	

## インロータイプ

型式	No.	D	D1	T	K	W	適用ボルト	¥基準単価	
								WLHM	WLHS
WLHM WLHS	4	20	14	6	4.5	M4	260	340	
	5	22	16	7	5.5	M5	300	380	
	6	26	18	8	6.6	M6	350	440	
	8	30	22	10	9	M8	390	500	
	10	38	28	12	11	M10	760	900	
	12	46	36	16	14	M12	840	1,000	

Order 注文例

型式 WLM5 WLHS4

Delivery 出荷日

在庫品 翌日出荷 目録発送 P81

ご希望によりPM5:00迄、当日出荷受付致します。

数量スライド価格 (①1円未満切り捨て) P81

数量	1~49	50~69	70~99	100~199
----	------	-------	-------	---------

WASHERS  
金属ワッシャ

THIN-WALLED COLLARS PIPE COLLARS SPACERS  
薄肉金属カラー パイプカラー / スペーサ

類似寸法は加工部品ナビガイドブック：P.129  
CADデータフォルダ名：35\_Washers

CADデータフォルダ名：35\_Washers

**LOWA**

材質 SS400

dH7	公差
3	$\pm 0.010$
4	$\pm 0.012$
5	$\pm 0.015$
6	$\pm 0.015$
8	$\pm 0.015$
10	$\pm 0.018$
12	$\pm 0.018$
16	$\pm 0.018$

**SRW**

材質 SS400

**SSWA**

材質 SS400

**T・R**

材質 S45C  
硬度 48~52HRC

**K・W**

材質 S45C  
硬度 48~52HRC

d	t	公差
K	+0.3 +0.1	$\pm 0.005$
W	+0.2 +0.1	$\pm 0.01$

**SW**

材質 S45C  
硬度 48~52HRC

型式 Type	d	D	t	¥基準単価			
				1~49コ	50~99	100~200	201~300
LOWA	3	6	5	80	70	65	60
	4	10					
	5	14					
	6	18	8	100	90	85	80
	8	22					
	10	25					
12	32	10	200	180	170	160	
16	32		270	250	240	230	

D	d	t	型式	¥基準単価				
				1~49コ	50~199	200~499	500~1000	
12	5.3	3	SRW	8	100	95	85	
15	5.3	3		10	100	95	85	
19	6.4	4		13	120	114	108	102
22	6.4	4	SRW	16	120	114	108	102
26	8.4	5		20	150	142	135	127
30	8.4	5		25	150	142	135	127

d	型式 Type	D	t	¥基準単価				
				t=1.0	t=2.0	t=3.0	t=4.0	t=5.0
3	SSWA	5	1.0	75	75	75	85	95
5		7						
6		9						
7		11.5						
8		13						
9	SSWA	15	2.0	85	85	85	95	110
10		17						
12		19						
12	SSWA	21	3.0	95	95	95	100	120
14.5		24						
15		26						
17		29						
20		34						
23	SSWA	39	5.0	110	110	110	120	140
23		39						

数量スライド価格 SSWA 20~49本5%引 50~199本10%引 200~500本15%引 501以上 見積り

D	d	型式	¥基準単価				
			1~49コ	50~199	200~499	500~1000	
11.5	4	T	6.5	70	66	63	59
13	5		8				
15	6		10				
18	8		13				
21	10		16				
23	12	20	120	114	108	102	
16	4	R	6.5~16	100	95	90	85
18	5		6.5~18				
20	5		8~18				
22	5		8~22				
25	6		10~22				
27	6	10~25					
27	8	R	10~27	130	123	117	110
25	8		13~25				
30	8		13~30				
30	10		16~30				
35	10		16~35				
40	12	20~35	260	247	234	221	
40	12	20~40					
10	6	K	10	60	57	54	51
13	8		13	70	66	63	59
16	10		16	80	76	72	68
20	12		20	90	85	81	76
8	5		W	10	60	57	54
11	6	13		70	66	63	59
14	8	16		80	76	72	68
17	10	20		90	85	81	76
17	10	20					

D	d	t	型式	¥基準単価				
				1~19コ	20~49	50~99	100~200	
10	4.5	3	SW	10	140	133	126	119
12	5.5			12				
16	6.5			12~6	150	142	135	127
20	8	4	SW	16	170	161	153	144
22	10			20				
25	12			22	180	171	162	153
27	12	5	SW	25	190	180	171	161
30	13			30	220	209	198	187
35	16			35	270	256	243	229
40	16	8	SW	40	320	304	288	272
50	20			50	320	304	288	272

D	d	t	型式	¥基準単価				
				1~19コ	20~49	50~99	100~200	
10	4.5	3	SW	10	140	133	126	119
12	5.5			12				
16	6.5			12~6	150	142	135	127
20	8	4	SW	16	170	161	153	144
22	10			20				
25	12			22	180	171	162	153
27	12	5	SW	25	190	180	171	161
30	13			30	220	209	198	187
35	16			35	270	256	243	229
40	16	8	SW	40	320	304	288	272
50	20			50	320	304	288	272

D	d	t	型式	¥基準単価				
				1~19コ	20~49	50~99	100~200	
10	4.5	3	SW	10	140	133	126	119
12	5.5			12				
16	6.5			12~6	150	142	135	127
20	8	4	SW	16	170	161	153	144
22	10			20				
25	12			22	180	171	162	153
27	12	5	SW	25	190	180	171	161
30	13			30	220	209	198	187
35	16			35	270	256	243	229
40	16	8	SW	40	320	304	288	272
50	20			50	320	304	288	272

**薄肉金属カラー**

材質 SUS304

Type	公差
3.0~10.0	$\pm 0.05$
10.5~20.0	$\pm 0.1$

Type	材質
TASC	SUS304

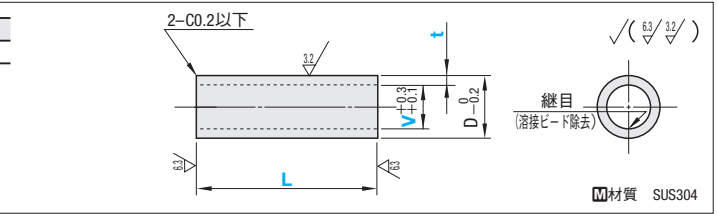

**TASC**

材質 SUS304

型式 Type	V	t	L	D	¥基準単価					
					10.5	t1	L3.0~5.0	L5.5~10.0	L10.5~15.0	L15.5~20.0
TASC	1	0.5	3.0	20.0	2	3	300	310	330	340
	1.5				2.5	3.5	300	320	330	350
	2				3	4	300	320	340	350
	2.5				3.5	4.5	340	360	380	390
	3				4	5	340	360	380	390
	3.5				4.5	5.5	340	360	380	400
4	5	6	430	450	470	490				
5	6	7	430	450	470	490				

Order 注文例 型式 - t - L  
TASC1 - 0.5 - 3.0

Delivery 出荷日 3 日発送 ストック A 200円/1本 P82  
同一サイズ3本以上は一律540円

Price 価格 数量スライド価格 (1円未満切り捨て) P81  
数量 1~19 20~39 40~49 50~99 表示数量を超えは  
値引率 基準単価 5% 10% 18% 見積り

**パイプカラー**

材質 SUS304

Type	材質	表面処理
SGP	SGP	-
SGPBB	SGP	四三酸化鉄皮膜
STPG	STPG370 (Sch40)	-
STPGB	STPG370 (Sch40)	四三酸化鉄皮膜
STPGH	STPG370 (Sch80)	-
STPGHB	STPG370 (Sch80)	四三酸化鉄皮膜

内径部には溶接継目があります。  
SGP・SGPBBのみ内側に0.5~1mmの盛り上がりがあります。

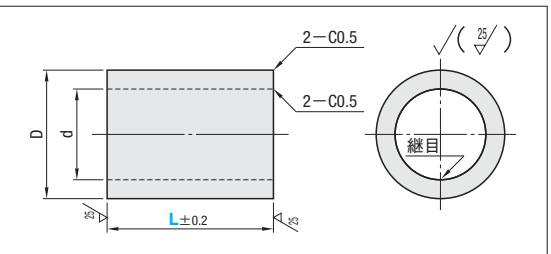

**SGP**

材質 SUS304

型式 Type	No.	L	D	¥基準単価																																																																																																																																																																																																																																																																																																																																																																																																																																																																																																																																																			
				SGP	SGPBB	STPG	STPGB	STPGH	STPGHB	L6~80	L80.5~130	L130.5~200	L6~80	L80.5~130	L130.5~200	L6~80	L80.5~130	L130.5~200	L6~80	L80.5~130	L130.5~200	L6~80	L80.5~130	L130.5~200																																																																																																																																																																																																																																																																																																																																																																																																																																																																																																																															
SGP	6A	6.0~80.0	10.5	6.5	7.1	5.7	260	-	-	280	-	-	300	-	-	320	-	-	340	-	-	360	-	-	380	-	-	400	-	-	420	-	-	440	-	-	460	-	-	480	-	-	500	-	-	520	-	-	540	-	-	560	-	-	580	-	-	600	-	-	620	-	-	640	-	-	660	-	-	680	-	-	700	-	-	720	-	-	740	-	-	760	-	-	780	-	-	800	-	-	820	-	-	840	-	-	860	-	-	880	-	-	900	-	-	920	-	-	940	-	-	960	-	-	980	-	-	1000	-	-	1020	-	-	1040	-	-	1060	-	-	1080	-	-	1100	-	-	1120	-	-	1140	-	-	1160	-	-	1180	-	-	1200	-	-	1220	-	-	1240	-	-	1260	-	-	1280	-	-	1300	-	-	1320	-	-	1340	-	-	1360	-	-	1380	-	-	1400	-	-	1420	-	-	1440	-	-	1460	-	-	1480	-	-	1500	-	-	1520	-	-	1540	-	-	1560	-	-	1580	-	-	1600	-	-	1620	-	-	1640	-	-	1660	-	-	1680	-	-	1700	-	-	1720	-	-	1740	-	-	1760	-	-	1780	-	-	1800	-	-	1820	-	-	1840	-	-	1860	-	-	1880	-	-	1900	-	-	1920	-	-	1940	-	-	1960	-	-	1980	-	-	2000	-	-	2020	-	-	2040	-	-	2060	-	-	2080	-	-	2100	-	-	2120	-	-	2140	-	-	2160	-	-	2180	-	-	2200	-	-	2220	-	-	2240	-	-	2260	-	-	2280	-	-	2300	-	-	2320	-	-	2340	-	-	2360	-	-	2380	-	-	2400	-	-	2420	-	-	2440	-	-	2460	-	-	2480	-	-	2500	-	-	2520	-	-	2540	-	-	2560	-	-	2580	-	-	2600	-	-	2620	-	-	2640	-	-	2660	-	-	2680	-	-	2700	-	-	2720	-	-	2740	-	-	2760	-	-	2780	-	-	2800	-	-	2820	-	-	2840	-	-	2860	-	-	2880	-	-	2900	-	-	2920	-	-	2940	-	-	2960	-	-	2980	-	-	3000	-	-	3020	-	-	3040	-	-	3060	-	-	3080	-	-	3100	-	-	3120	-	-	3140	-	-	3160	-	-	3180	-	-	3200	-	-	3220	-	-	3240	-	-	3260	-	-	3280	-	-	3300	-	-	3320	-	-	3340	-	-	3360	-	-	3380	-	-	3400	-	-	3420	-	-	3440	-	-	3460	-	-	3480	-	-	3500	-	-	3520	-	-	3540	-	-	3560	-	-	3580	-	-	3600	-	-	3620	-	-	3640	-	-	3660	-	-	3680	-	-	3700	-	-	3720	-	-	3740	-	-	3760	-	-	3780







COLLARS - STANDARD TYPE-

# 金属カラー

一並級/精密級 寸法フリー指定タイプ



CADデータフォルダ名: 35\_Washers

類似寸法は加工部品Cナビガイドブック: P.133・134



型式	材質	表面処理	硬度
並級	精密級		
FNCL	FAC	①	SS400
FNCL	FACS	②	S45C
FNCLB	FABSC	③	
FNCLM	FAMSC	④	
FNCLR	FARSC	⑤	
FNCLBB	-	⑥	黄銅(C3604)
FNCLA	FAASC	⑦	A2017
FNCLAB	-	⑧	SUS304
FNCLSS	FSASC	⑨	
FNCLSSR	FSASCR	⑩	S45C
FNCLCH	FAS	⑪	
FNCLBH	FASC	⑫	
FNCLMH	FPASC	⑬	
FNCSK	FASK	⑭	SKS3
FNCSKB	FASKB	⑮	
FNCSKM	FASKM	⑯	SUS420J2
FNCLSH	FSASCH	⑰	
FNCLSHR	FSASCHR	⑱	

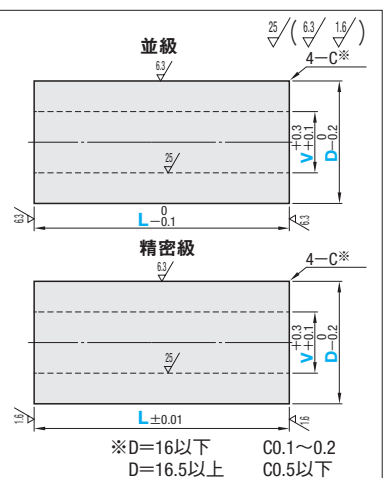

① ステンレス焼入タイプは焼入により変色する場合があります。  
② 低温黒色クロムメッキは内径が処理されない場合があります。

並級・精密級 共通加工条件  
\*1 肉厚と全長の加工限界  
10.0 ≤ L ≤ 50.0 → (D-V)/2 ≥ 1  
50.5 ≤ L ≤ 100.0 → (D-V)/2 ≥ 3

\*2 肉厚と全長の加工限界 (材質A2017・SKS3・黄銅)  
4 ≤ D ≤ 10 → V ≤ D-2  
10.5 ≤ D ≤ 30 → V ≤ D-4  
31 ≤ D ≤ 60 → V ≤ D-6  
61 ≤ D ≤ 80 → V ≤ D-8  
81 ≤ D ≤ 100 → V ≤ D-10

\*3 Vと全長の加工限界  
L ≤ V × 8

## 並級

型式	V 指定0.5mm単位 (V寸3以上)	D	L 指定0.5mm単位	¥基準単価																	
				①	②	③	④	⑤	⑥	⑦	⑧	⑨	⑩	⑪	⑫	⑬	⑭	⑮	⑯	⑰	
FNCL FNCLC FNCLB FNCLM FNCLR FNCLBB FNCLA FNCLAB FNCLSS FNCLSSR FNCLCH FNCLBH FNCLMH FNCSK FNCSKB FNCSKM FNCLSH FNCLSHR	4.0~10.0 (0.5mm単位)	10.0	10.0~25.0	280	280	320	410	410	340	350	510	620	360	400	510	420	460	600	720	780	
			25.0~50.0	360	370	420	520	510	540	470	680	810	470	520	650	550	610	760	960	1,020	1,020
			50.5~75.0	530	540	600	700	710	640	650	970	1,120	680	750	880	790	880	1,040	1,380	1,440	1,440
	10.5~20.0 (0.5mm単位)	10.0	10.0~25.0	360	370	410	510	500	450	450	660	730	460	510	640	540	600	750	940	990	990
			25.0~50.0	520	530	590	700	760	870	640	950	1,090	670	740	870	780	870	1,030	1,350	1,460	1,460
			50.5~75.0	720	730	800	930	1,030	1,170	900	1,320	1,580	920	1,010	1,160	1,080	1,180	1,370	1,870	2,100	2,100
	21~30 (1mm単位)	10.0	10.0~25.0	360	370	420	520	590	690	470	670	870	470	520	650	550	610	760	960	1,140	1,140
			25.0~50.0	550	560	620	730	900	1,170	1,310	1,110	1,310	770	920	820	910	1,080	1,420	1,710	1,710	1,710
			50.5~75.0	730	740	820	950	1,270	1,720	900	1,330	1,810	930	1,040	1,190	1,090	1,220	1,400	1,880	2,340	2,340
	31~40 (1mm単位)	10.0	10.0~25.0	650	660	720	840	1,010	1,030	800	1,400	1,500	830	910	1,050	970	1,070	1,240	1,670	1,960	1,960
			25.0~50.0	870	880	970	1,110	1,540	1,840	1,070	2,400	2,600	1,110	1,220	1,390	1,300	1,430	1,630	2,260	2,810	2,810
			50.5~75.0	1,230	1,250	1,380	1,530	2,240	2,530	1,520	3,450	3,700	1,560	1,730	1,920	1,830	2,030	2,260	3,140	3,870	3,870
41~50 (1mm単位)	10.0	10.0~25.0	1,400	1,430	1,590	1,750	2,720	3,350	1,750	5,000	5,250	1,780	1,980	2,010	2,100	2,330	2,360	3,290	5,450	5,450	
		25.0~50.0	660	670	740	870	1,190	1,570	810	1,450	1,680	840	930	1,080	980	1,090	1,270	1,700	2,160	2,160	
		50.5~75.0	870	880	980	1,120	1,840	2,650	1,080	2,480	2,690	1,110	1,220	1,400	1,300	1,440	1,640	2,370	3,150	3,150	
51~60 (1mm単位)	10.0	10.0~25.0	1,280	1,290	1,440	1,600	2,760	3,940	1,580	3,570	3,830	1,620	1,800	1,990	1,910	2,120	2,340	3,850	4,460	4,460	
		25.0~50.0	1,470	1,490	1,650	1,830	3,430	5,240	1,830	5,130	5,390	1,860	2,090	2,190	2,230	2,480	5,380	5,590	5,590	5,590	
		50.5~75.0	810	820	920	1,000	1,540	2,240	980	1,500	1,920	1,040	1,140	1,250	1,220	1,340	1,470	1,810	2,450	2,450	
61~80 (1mm単位)	10.0	10.0~25.0	1,150	1,170	1,290	1,320	2,560	4,060	1,290	2,560	3,000	1,470	1,620	1,730	1,910	1,960	2,280	3,730	3,730	3,730	
		25.0~50.0	1,470	1,490	1,660	1,780	3,600	5,750	1,800	3,690	4,330	1,870	2,080	2,220	2,200	2,450	2,620	4,020	5,400	5,400	
		50.5~75.0	1,770	1,790	1,990	2,190	4,520	7,080	2,180	5,260	5,150	2,240	2,490	2,740	2,640	2,940	3,220	5,450	6,640	6,640	
81~100 (1mm単位)	10.0	10.0~25.0	1,440	1,450	1,930	1,950	3,060	4,360	1,420	1,840	2,860	2,100	2,610	2,680	2,960	3,680	3,790	2,630	3,790	3,790	
		25.0~50.0	2,090	2,110	2,560	2,560	4,860	6,700	1,880	2,950	4,530	2,780	3,300	3,380	3,920	4,670	4,770	3,560	5,840	5,840	
		50.5~75.0	2,560	2,640	3,130	3,160	6,660	9,020	2,610	4,250	6,600	3,410	3,950	4,020	4,820	5,580	5,690	5,040	8,490	8,490	
3.0~90.0 (指定0.5mm単位)	10.0	10.0~25.0	3,000	3,150	3,670	3,690	8,340	10,940	3,160	6,050	7,920	3,990	4,550	4,620	5,630	6,420	6,530	6,850	10,450	10,450	
		25.0~50.0	1,590	1,600	2,110	2,170	3,890	6,690	1,720	2,120	3,840	2,300	2,880	2,950	3,260	4,060	4,170	3,170	4,980	4,980	
		50.5~75.0	2,290	2,320	2,800	2,830	6,390	10,320	2,270	3,400	6,230	3,050	3,640	3,710	4,310	5,130	5,240	4,280	7,850	7,850	
3.0~90.0 (指定0.5mm単位)	10.0	10.0~25.0	2,810	2,880	3,440	3,470	8,890	14,230	3,160	4,890	9,110	3,740	4,340	4,410	5,280	6,130	6,240	6,080	11,460	11,460	
		25.0~50.0	3,290	3,450	4,020	4,040	11,270	18,110	3,810	6,960	11,100	4,370	4,990	5,060	6,170	7,050	7,150	7,120	14,250	14,250	

共通加工条件 \*1\*2\*3

Alteration 追加加工  
型式 - V - D - L - (VKC・DKC・HKC)  
FNCLB - V10.5 - D45 - L70.5 - VKC

① 内径公差変更と外径公差変更を両方指定した場合、同軸度はφ0.02となります。  
② 焼入れ品 (硬度表記のあるもの)・アルマイト(黒色)品は適用不可。

Alteration 追加加工  
型式 - V - D - L - (VKC・DKC・HKC)  
FNCLB - V10.5 - D45 - L70.5 - VKC

Alteration	Code	Spec.	¥/1Code																						
内径公差変更	VKC	内径の公差をH7に変更します。 指定方法 VKC 加工条件 V ≥ 8でL ≥ V × 5の場合には右記の中逃しが付きます。	400																						
		<table border="1"> <tr> <th>D</th> <th>D-V</th> </tr> <tr> <td>6~10</td> <td>D-V ≥ 2</td> </tr> <tr> <td>10.5~20</td> <td>D-V ≥ 3</td> </tr> <tr> <td>21~30</td> <td>D-V ≥ 6</td> </tr> <tr> <td>31~40</td> <td>D-V ≥ 8</td> </tr> <tr> <td>41~50</td> <td>D-V ≥ 10</td> </tr> <tr> <td>51~60</td> <td>D-V ≥ 12</td> </tr> <tr> <td>61~70</td> <td>D-V ≥ 14</td> </tr> <tr> <td>71~80</td> <td>D-V ≥ 16</td> </tr> <tr> <td>81~90</td> <td>D-V ≥ 18</td> </tr> <tr> <td>91~100</td> <td>D-V ≥ 20</td> </tr> </table>	D	D-V	6~10	D-V ≥ 2	10.5~20	D-V ≥ 3	21~30	D-V ≥ 6	31~40	D-V ≥ 8	41~50	D-V ≥ 10	51~60	D-V ≥ 12	61~70	D-V ≥ 14	71~80	D-V ≥ 16	81~90	D-V ≥ 18	91~100	D-V ≥ 20	
D	D-V																								
6~10	D-V ≥ 2																								
10.5~20	D-V ≥ 3																								
21~30	D-V ≥ 6																								
31~40	D-V ≥ 8																								
41~50	D-V ≥ 10																								
51~60	D-V ≥ 12																								
61~70	D-V ≥ 14																								
71~80	D-V ≥ 16																								
81~90	D-V ≥ 18																								
91~100	D-V ≥ 20																								

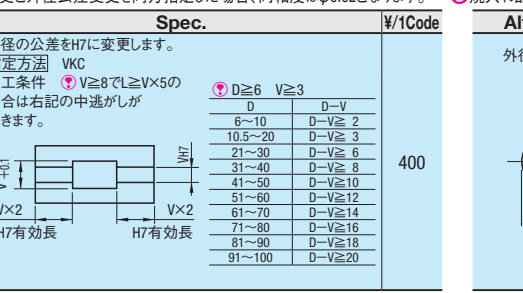

Alteration	Code	Spec.	¥/1Code																						
外径公差変更	DKC (g6) HKC (h7)	外径の公差をg6もしくはh7に変更します。 指定方法 DKC・HKC 加工条件 D ≥ 6	500																						
		<table border="1"> <tr> <th>D</th> <th>D-V</th> </tr> <tr> <td>6~10</td> <td>D-V ≥ 2</td> </tr> <tr> <td>10.5~20</td> <td>D-V ≥ 3</td> </tr> <tr> <td>21~30</td> <td>D-V ≥ 6</td> </tr> <tr> <td>31~40</td> <td>D-V ≥ 8</td> </tr> <tr> <td>41~50</td> <td>D-V ≥ 10</td> </tr> <tr> <td>51~60</td> <td>D-V ≥ 12</td> </tr> <tr> <td>61~70</td> <td>D-V ≥ 14</td> </tr> <tr> <td>71~80</td> <td>D-V ≥ 16</td> </tr> <tr> <td>81~90</td> <td>D-V ≥ 18</td> </tr> <tr> <td>91~100</td> <td>D-V ≥ 20</td> </tr> </table>	D	D-V	6~10	D-V ≥ 2	10.5~20	D-V ≥ 3	21~30	D-V ≥ 6	31~40	D-V ≥ 8	41~50	D-V ≥ 10	51~60	D-V ≥ 12	61~70	D-V ≥ 14	71~80	D-V ≥ 16	81~90	D-V ≥ 18	91~100	D-V ≥ 20	
D	D-V																								
6~10	D-V ≥ 2																								
10.5~20	D-V ≥ 3																								
21~30	D-V ≥ 6																								
31~40	D-V ≥ 8																								
41~50	D-V ≥ 10																								
51~60	D-V ≥ 12																								
61~70	D-V ≥ 14																								
71~80	D-V ≥ 16																								
81~90	D-V ≥ 18																								
91~100	D-V ≥ 20																								

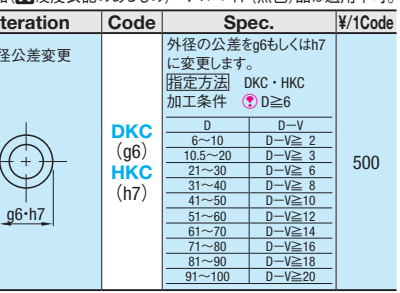

## 精密級

型式	V 指定0.5mm単位 (V寸3以上)	D	L 指定0.1mm単位	¥基準単価																	
				①	②	③	④	⑤	⑦	⑧	⑨	⑩	⑪	⑫	⑬	⑭	⑮	⑯	⑰		
FAC FACS FABSC FAMSC FARSC FAASC FSASC FSASCR FAS FASC FPASC FASK FASKB FASKM FSASCH FSASCHR	4.0~10.0 (0.5mm単位)	10.0	10.0~25.0	400	420	450	650	480	470	750	810	520	570	740	620	680	880	1,040	1,230	1,230	
			25.1~50.0	530	560	590	820	620	630	930	1,070	680	760	940	810	910	1,120	1,400	1,620	1,620	1,620
			50.1~75.0	760	810	850	1,120	860	900	1,360	1,510	970	1,080	1,280	1,170	1,300	1,530	1,990	2,280	2,960	2,960
	10.5~20.0 (0.5mm単位)	10.0	10.0~25.0	460	490	530	720	550	620	880	940	590	670	830	710	800	990	1,220	1,420	1,420	1,420
			25.1~50.0	670	720	750	990	830	920	1,230	1,390	860	950	1,130	1,040	1,140	1,360	1,760	2,090	2,090	2,090
			50.1~75.0	930	980	1,020	1,310	1,210	1,190	1,650	2,000	1,190	1,310	1,500	1,430	1,570	1,810	2,430	2,980	2,980	2,980
	21~30 (1mm単位)	10.0	10.0~25.0	1,120	1,190	1,250	1,580	1,470	1,530	1,880	2,430	1,430	1,590	1,790	1,720	1,900	2,150	2,800	3,460	3,460	3,460
			25.1~50.0	470	500	530	730	680	630	900	1,080	600	680	840	720	810	1,000	1,250	1,600	1,600	1,600
			50.1~75.0	710	750	770	1,010	1,040	1,140	1,580	1,630	910	1,000	1,150	1,090	1,200	1,380	1,830	2,380	2,380	2,380
	31~40 (1mm単位)	10.0	10.0~25.0	940	990	1,040	1,320	1,580	1,530	2,590	2,790	1,220	1,330	1,500	1,460	1,600	1,810	2,870	3,280	3,280	3,280
			25.1~50.0	1,340	1,410	1,480	1,840	2,300	2,160	3,650	3,900	1,710	1,870	1,960	2,050	2,250	2,360	3,940	4,490	4,490	4,490
			50.1~75.0	1,530	1,620	1,710	2,100	2,800	2,480	5,210	5,460	1,960	2,030	2,180	2,350	2,430	2,620	5,500	5,660	5,660	5,660
41~50 (1mm単位)	10.0	10.0~25.0	720	760	800	1,040	1,300	1,170	1,630	1,940	920	1,020	1,190	1,100	1,220	1,430	1,860	2,630	2,630	2	



# 金属カラー

—並級/精密級 内外径公差選択・寸法フリー指定タイプ—



◎類似寸法は加工部品Cナビガイドブック:P.133・134

◎CADデータフォルダ名: 35\_Washers



型式	材質	表面処理
並級 精密級	S45C	—
SNCC SNMC SNCB SNMB SNCM SNMM SNCS SNMS	SUS304	四三酸化鉄皮膜 無電解ニッケルメッキ

D	D公差選択			
	G	H	N	X
5.0~8.5	—	—	—	—
9.0~10.0	-0.005 -0.014	0 -0.015	—	—
10.5~18.0	-0.006 -0.017	0 -0.018	-0.1 -0.3	0
18.5~30	-0.007 -0.020	0 -0.021	—	-0.2
31~50	-0.009 -0.025	0 -0.025	—	—
51~60	-0.010 -0.029	0 -0.030	—	—

内外径公差価格番号表		
D(外径)	V(内径)	価格番号
G	H	②
	N	①
	X	①
H	H	②
	N	①
	X	①
N	H	①
	N	③
	X	③
X	H	①
	N	③
	X	③

・価格表の見方  
例>材質S45C、外径g6、内径H7、L公差±0.01を注文する場合  
型式: SNMC-GH-V4.0-D10.0-L10.0  
1.内外径公差価格番号表を確認します。(GHは価格番号②)  
2.精密級の価格表から、内外径公差価格番号②の欄を参照します。  
3.D・L寸法より、価格1,290円

V	V公差選択		
	H7	N	X
3.0	+0.010 0	—	—
3.5~6.0	+0.012 0	—	—
6.5~10.0	+0.015 0	—	—
10.5~18.0	+0.018 0	+0.3 +0.1	+0.2 0
18.5~30.0	+0.021 0	—	—
30.5~50.0	+0.025 0	—	—
50.5~58.0	+0.030 0	—	—

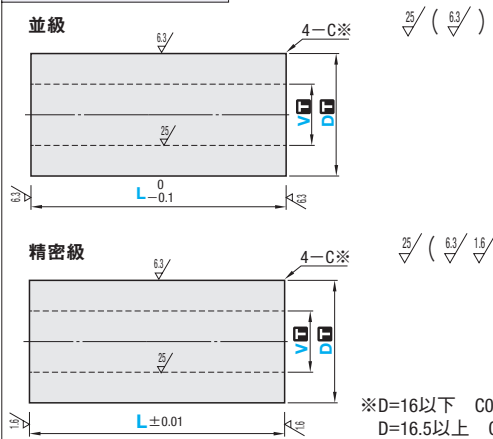

※D=16以下 C0.1~0.2  
D=16.5以上 C0.5以下

型式	D公差選択	V公差選択	V指定0.5mm単位	D	L指定0.5mm単位	¥基準単価																
						SNCC				SNCB				SNCM				SNCS				
						公差①	公差②	公差③	公差④	公差①	公差②	公差③	公差④	公差①	公差②	公差③	公差④	公差①	公差②	公差③	公差④	
SNCC SNCB SNCM SNCS	G H N X	H N X	3.0~58.0 (V≤D-2) ◎下記参照	5.0~10.0 0.5mm単位	10.0~25.0	630	1,050	280	670	1,070	320	830	1,230	510								
					25.5~50.0	720	1,120	370	750	1,150	420	940	1,370	520	980	1,360	680					
					50.5~64.0	860	1,250	540	910	1,300	600	1,120	1,540	700	1,230	1,590	970					
					10.5~20.0 0.5mm単位	10.0~25.0	710	1,120	370	740	1,140	410	930	1,370	510	960	1,340	660				
					25.5~50.0	850	1,240	530	900	1,290	590	1,120	1,530	700	1,210	1,580	950					
					50.5~75.0	1,020	1,400	730	1,080	1,460	800	1,330	1,740	930	1,530	1,870	1,320					
				21~30 1mm単位	10.0~25.0	720	1,120	370	750	1,150	420	940	1,370	520	980	1,360	670					
					25.5~50.0	870	1,260	560	920	1,310	620	1,140	1,560	730	1,250	1,620	1,010					
					50.5~75.0	1,030	1,410	740	1,100	1,470	820	1,350	1,750	950	1,530	1,870	1,330					
					75.5~100.0	1,170	1,540	910	1,250	1,620	920	1,530	1,920	1,140	1,800	2,110	1,630					
					10.0~25.0	960	1,340	660	1,020	1,400	720	1,250	1,660	840	1,670	2,080	1,400					
					25.5~50.0	1,150	1,520	880	1,230	1,590	970	1,500	1,900	1,110	2,660	3,140	2,400					
				31~40 1mm単位	50.5~75.0	1,470	1,810	1,250	1,580	1,910	1,380	1,910	2,280	1,530	3,570	3,990	3,450					
					75.5~100.0	1,620	1,950	1,430	1,750	2,080	1,590	2,110	2,470	1,750	5,040	5,540	5,000					
					10.0~25.0	960	1,350	670	1,030	1,410	740	1,270	1,690	870	1,720	2,140	1,450					
					25.5~50.0	1,150	1,520	880	1,240	1,590	980	1,510	1,900	1,120	2,710	3,220	2,480					
					50.5~75.0	1,510	1,850	1,290	1,630	1,960	1,440	1,970	2,320	1,600	3,660	4,080	3,570					
					75.5~100.0	1,670	1,990	1,490	1,810	2,130	1,650	2,190	2,530	1,830	5,150	5,610	5,130					
				41~50 1mm単位	10.0~25.0	1,100	1,470	820	1,180	1,540	920	1,400	1,800	1,000	1,750	2,140	1,500					
					25.5~50.0	1,400	1,750	1,170	1,510	1,850	1,290	1,710	2,090	1,320	2,780	3,240	2,560					
					50.5~75.0	1,680	2,000	1,490	1,810	2,140	1,660	2,140	2,480	1,780	3,770	4,160	3,690					
					75.5~100.0	1,930	2,240	1,790	2,100	2,390	1,990	2,540	2,850	2,190	5,300	5,800	5,260					
					10.0~25.0	1,100	1,470	820	1,180	1,540	920	1,400	1,800	1,000	1,750	2,140	1,500					
					25.5~50.0	1,400	1,750	1,170	1,510	1,850	1,290	1,710	2,090	1,320	2,780	3,240	2,560					
51~60 1mm単位	50.5~75.0	1,680	2,000	1,490	1,810	2,140	1,660	2,140	2,480	1,780	3,770	4,160	3,690									
	75.5~100.0	1,930	2,240	1,790	2,100	2,390	1,990	2,540	2,850	2,190	5,300	5,800	5,260									
	10.0~25.0	1,100	1,470	820	1,180	1,540	920	1,400	1,800	1,000	1,750	2,140	1,500									
	25.5~50.0	1,400	1,750	1,170	1,510	1,850	1,290	1,710	2,090	1,320	2,780	3,240	2,560									
	50.5~75.0	1,680	2,000	1,490	1,810	2,140	1,660	2,140	2,480	1,780	3,770	4,160	3,690									
	75.5~100.0	1,930	2,240	1,790	2,100	2,390	1,990	2,540	2,850	2,190	5,300	5,800	5,260									

◎D・V公差にGまたはHを選択した場合は、D≥9の適用となります。◎Vと全長の加工限界 L≤V×8  
◎D・V公差にHを選択し、V≥8でL≥V×4のとき中逃しが付きます。

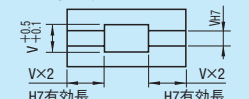

Order注文例: 型式 - 公差選択 - V - D - L  
Price価格: SNCS - G H - V10.0 - D25 - L50.5

数量スライド価格 (◎1円未満切り捨て) P81

数量	1~9	10~19	20~29	30~49	50~100	101以上
値引率	—	5%	10%	15%	18%	出荷日・価格
出荷日	—	通常	—	—	+3日	共にお見積

◎101円以上お見積りになります。

Delivery出荷日: 3日目発送 | ストックA 200円/1本 | P82 | 大口出荷日+3日目出荷 | 数量50~100

Alteration追加加工: 右ページ追加加工

型式	D公差選択	V公差選択	V指定0.5mm単位	D	L指定0.5mm単位	¥基準単価															
						SNMC				SNMB				SNMM				SNMS			
						公差①	公差②	公差③	公差④	公差①	公差②	公差③	公差④	公差①	公差②	公差③	公差④	公差①	公差②	公差③	公差④
SNMC SNMB SNMM SNMS	G H N X	H N X	3.0~58.0 (V≤D-2) ◎下記参照	5.0~10.0 0.5mm単位	10.0~25.0	790	1,290	450	820	1,320	500	900	1,400	680	1,020	1,520	750				
					25.5~50.0	910	1,410	590	960	1,450	650	1,040	1,530	860	1,240	1,740	930				
					50.5~64.0	1,130	1,630	850	1,190	1,680	940	1,270	1,760	1,170	1,600	2,100	1,360				
					10.5~20.0 0.5mm単位	10.0~25.0	840	1,340	520	870	1,370	580	960	1,460	760	1,130	1,630	880			
					25.5~50.0	1,020	1,530	750	1,080	1,580	830	1,170	1,670	1,020	1,460	1,950	1,230				
					50.5~75.0	1,250	1,750	1,030	1,320	1,810	1,140	1,420	1,920	1,340	1,870	2,360	1,650				
				21~30 1mm単位	75.5~100.0	1,430	1,930	1,250	1,520	2,020	1,380	1,640	2,130	1,600	2,180	2,670	1,880				
					10.0~25.0	850	1,340	530	880	1,380	590	960	1,470	760	1,150	1,640	900				
					25.5~50.0	1,060	1,550	790	1,110	1,610	870	1,210	1,700	1,090	1,510	2,010	1,250				
					50.5~75.0	1,270	1,760	1,050	1,340	1,840	1,150	1,450	1,940	1,370	1,870	2,370	1,690				
					75.5~100.0	1,460	1,960	1,280	1,550	2,040	1,420	1,660	2,150	1,630	2,210	2,710	2,010				
					10.0~25.0	1,020	1,530	790	1,090	1,580	860	1,190	1,680	1,060	1,290	2,550	1,580				
				31~40 1mm単位	25.5~50.0	1,240	1,740	1,050	1,320	1,810	1,160	1,440	1,930	1,350	3,020	3,830	2,590				
					50.5~75.0	1,580	2,090	1,490	1,700	2,210	1,610	1,840	2,330	1,860	4,020	4,820	3,650				
					75.5~100.0	1,760	2,260	1,710	1,900	2,400	1,810	2,040	2,540	2,130	5,730	6,840	5,210				
					10.0~25.0	1,030	1,530	800	1,100	1,590	890	1,210	1,700	1,110	1,960	2,590	1,630				
					25.5~50.0	1,240	1,740	1,070	1,330	1,820	1,180	1,440	1,930	1,430	3,090	3,910	2,670				
					50.5~75.0	1,640	2,140	1,540	1,760	2,260	1,710	1,930	2,390	1,950	4,190	4,980	3,770				
				41~50 1mm単位	75.5~100.0	1,820	2,320	1,780	1,970	2,460	1,870	2,110	2,610	2,200	5,800	6,790	5,340				
					10.0~25.0	1,190	1,680	990	1,270	1,760	1,090	1,420	1,920	1,370	2,100	2,760	1,680				
					25.5~50.0	1,510	2,010	1,340	1,620	2,120	1,450	1,750	2,210	1,670	3,150	3,930	2,750				
					50.5~75.0	1,820	2,320	1,790	1,970	2,460	1,900	2,110	2,560	2,130	4,340	5,130	3,890				
					75.5~100.0	2,120	2,610														



# COLLARS-SHOULDER TYPE- 金属カラー

ツバ付タイプ 並級/精密級



類似寸法は加工部品Cナビガイドブック：P.134

CADデータフォルダ名：35\_Washers



Type	フリー指定	材質	表面処理	硬度
並級	精密級	SS400	-	-
FTCLS	FTCLC	S45C	四酸化鉄皮膜 無電解ニッケルメッキ	-
FTCLB	FTCLM			
TCLB	FTCLMB			
TCLM	FTCLMM			
FTCLBB	-	黄銅(C3604)	-	-
TCLA	FTCLA	A2017	アルマイト(白色) アルマイト(黒色)	-
FTCLAB	-			
TCLSS	FTCLSS	SUS304	-	-
FTCLCH	FTCLBH	S45C	四酸化鉄皮膜 無電解ニッケルメッキ	45~50HRC
FTCLMH	FTCLSK			
FTCLSKB	FTCLSKM			
FTCLSKM	-			
FTCLSH	FTCMSH	SUS420J2	-	45~50HRC

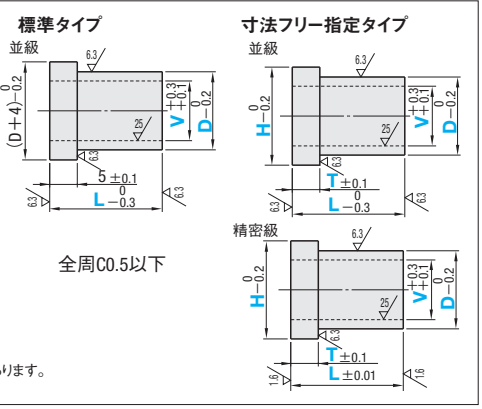

### 標準タイプ 並級

型式	V	D	L
Type	2 5 6 8 10	選択	指定0.1mm単位
	3 5 6 8 10 12		10.0~16.0
	4 6 8 10 12 13 14 15 16 20		10.0~50.0
	5 8 10 12 13 14 15 16 20		
	6 8 10 12 13 14 15 16 20 25		
	10 12 13 14 15 16 20 25 30		
	12 13 14 15 16 20 25 30 35 40 50		
	15 16 20 25 30 35 40 50 60		10.0~100.0
	16 20 25 30 35 40 50 60		
	20 25 30 35 40 50 60		
	25 30 35 40 50 60		
	30 40 50 60		

型式	V	10.0~25.0	25.1~50.0	50.1~75.0	75.1~100.0
Type	2	270	-	-	-
	3 4 5	270	290	-	-
	6	320	350	-	-
	8 10	360	390	420	450
	12	380	410	440	470
	15	410	440	470	500
	16	440	470	500	540
	20	500	530	550	580
	25	550	600	640	680
	30	590	670	740	770

型式	V	10.0~25.0	25.1~50.0	50.1~75.0	75.1~100.0
Type	2	320	-	-	-
	3 4 5	320	340	-	-
	6	370	390	-	-
	8 10	410	450	500	530
	12	440	470	510	560
	15	480	500	560	580
	16	510	560	580	620
	20	580	600	630	670
	25	630	690	730	760
	30	680	760	820	860

Order 注文例  
型式 - D - L  
TCLB10 - 20 - 60.0

Delivery 出荷日  
●材質S45C・SUS304・黄銅 ●材質A2017  
3 日目発送 ●ストークA 200円/1本 ●P82 ●ストークB 200円/1本 ●P82  
◎同一サイズ3本以上は一律540円 ◎同一サイズ3本以上は一律540円

### 寸法フリー指定タイプ 並級

型式	V	D	H	T	L	¥基準単価												
						FTCLS	FTCLC	FTCLB	FTCLM	FTCLBB	FTCLA	FTCLAB	FTCLSS	FTCLCH	FTCLBH	FTCLMH	FTCLSK	FTCLSKB
FTCLS FTCLC FTCLB FTCLM FTCLBB FTCLA FTCLAB FTCLSS FTCLCH FTCLBH FTCLMH FTCLSK FTCLSKB FTCLSKM FTCLSH	指定0.5mm単位 (V寸3以上)	4.0~10.0 (0.5mm単位)	6.0~20.0 (0.5mm単位)	1~20 (T≤L-1)	10.0~25.0 25.1~50.0 50.1~75.0 75.1~100.0	650	730	790	810	640	860	840	900	940	1,070	1,140	1,190	1,270
						910	1,010	1,140	1,190	820	1,250	1,170	1,300	1,370	1,490	1,640	1,740	1,620
						1,170	1,310	1,500	1,580	1,010	1,670	1,520	1,710	1,820	1,920	2,160	2,300	1,990
	(選択)	10.5~20 (0.5mm単位)	12.5~30 (0.5mm単位)	1~20 (T≤L-1)	10.0~25.0 25.1~50.0 50.1~75.0 75.1~100.0	920	1,020	1,160	1,230	860	1,300	1,190	1,330	1,410	1,510	1,690	1,790	1,690
						1,330	1,490	1,770	1,890	1,190	1,980	1,720	2,010	2,170	2,180	2,550	2,750	2,350
						1,740	1,930	2,370	2,550	1,540	2,680	2,260	2,690	2,940	2,860	3,420	3,720	3,040
	(指定)	21~30 (1mm単位)	23~40 (1mm単位)	1~20 (T≤L-1)	10.0~25.0 25.1~50.0 50.1~75.0 75.1~100.0	1,210	1,340	1,600	1,710	1,140	1,790	1,570	1,830	1,960	1,990	2,310	2,490	2,250
						1,760	1,960	2,470	2,680	1,650	2,820	2,280	2,820	3,080	2,900	3,570	3,910	3,230
						2,310	2,580	3,350	3,660	2,160	3,850	3,000	3,800	4,210	3,800	4,520	5,340	4,360
	3.0~55.0	31~40 (1mm単位)	33~50 (1mm単位)	1~20 (T≤L-1)	10.0~25.0 25.1~50.0 50.1~75.0 75.1~100.0	2,860	3,200	4,230	4,640	2,660	4,880	3,720	4,810	5,330	4,710	6,100	6,760	5,480
						1,530	1,710	2,100	2,280	1,490	2,390	1,990	2,390	2,620	2,520	3,030	3,310	2,910
						2,230	2,490	3,290	3,620	2,180	3,800	2,900	3,750	4,170	3,680	4,750	5,280	4,920
51~60 (1mm単位)	41~50 (1mm単位)	43~60 (1mm単位)	1~20 (T≤L-1)	10.0~25.0 25.1~50.0 50.1~75.0 75.1~100.0	2,940	3,280	4,490	5,000	2,880	5,260	3,810	5,100	5,740	4,840	6,460	7,280	5,860	
					3,650	4,060	5,680	6,320	3,580	6,630	4,730	6,450	7,260	5,990	8,160	9,200	7,390	
					1,900	2,110	2,690	2,930	1,890	3,080	2,470	3,060	3,370	3,120	3,890	4,260	3,700	
51~60 (1mm単位)	51~60 (1mm単位)	53~70 (1mm単位)	1~20 (T≤L-1)	10.0~25.0 25.1~50.0 50.1~75.0 75.1~100.0	2,760	3,080	4,230	4,700	2,800	4,940	3,590	4,820	5,400	4,550	6,110	6,840	5,500	
					3,620	4,040	5,770	6,470	3,750	6,800	4,700	6,560	7,440	5,950	8,320	9,430	7,540	
					4,480	5,000	7,310	8,250	4,700	8,420	5,810	8,320	9,480	7,360	10,540	12,010	9,570	
51~60 (1mm単位)	51~60 (1mm単位)	53~70 (1mm単位)	1~20 (T≤L-1)	10.0~25.0 25.1~50.0 50.1~75.0 75.1~100.0	2,310	2,580	3,370	3,680	2,410	3,870	3,000	3,820	4,230	3,800	4,850	5,370	4,730	
					3,330	3,720	5,300	5,930	3,610	6,230	4,320	6,030	6,820	5,480	7,630	8,640	7,080	
					4,360	4,860	7,220	8,170	4,830	8,250	5,660	8,220	9,400	7,170	10,420	11,910	9,670	
					5,390	6,010	7,640	8,340	6,060	8,440	6,990	9,570	10,730	8,860	11,000	12,130	11,880	

◎ D-Vの加工条件  
10.0≤L≤50.0 → (D-V)/2≥1  
50.1≤L≤100.0 → (D-V)/2≥3

◎ D-Vの加工条件  
(FTCLSK・FTCLSKB・FTCLSKM・FTCLBB)  
4≤D≤10 → V≤D-2  
10.5≤D≤30 → V≤D-4  
31≤D≤60 → V≤D-6

◎ H-D≥2 ◎ D/10≤L≤V×8

Order 注文例  
型式 - V - D - H - T - L  
FTCLB - V10.5 - D20 - H30 - T4 - L23.8

Delivery 出荷日  
●材質S45C・SUS304・黄銅 ●材質A2017・SUS420J2  
3 日目発送 ●ストークA 200円/1本 ●P82 ●ストークB 200円/1本 ●P82  
◎同一サイズ3本以上は一律540円 ◎同一サイズ3本以上は一律540円

### 寸法フリー指定タイプ 精密級

型式	V	D	H	T	L	¥基準単価			
						FTCLMC	FTCLMB	FTCLMM	FTCMSH
FTCLMC FTCLMB FTCLMM FTCMSH	指定0.5mm単位 (V寸3以上)	4.0~10.0 (0.5mm単位)	6.0~20.0 (0.5mm単位)	1.0~20.0	10.0~25.0	900	970	1,020	1,470
					25.1~50.0	1,210	1,340	1,410	1,840
					50.1~75.0	1,570	1,760	1,880	2,290
	(選択)	10.5~20 (0.5mm単位)	12.5~30 (0.5mm単位)	2.0~20.0	10.0~25.0	1,200	1,350	1,420	1,870
					25.1~50.0	1,680	1,970	2,100	2,550
					50.1~75.0	2,200	2,630	2,850	3,310
	(指定0.5mm単位)	21~30 (1mm単位)	23~40 (1mm単位)	3.0~20.0	10.0~25.0	1,510	1,760	1,870	2,400
					25.1~50.0	2,140	2,650	2,850	3,400
					50.1~75.0	2,820	3,580	3,900	4,590
	31~40 (1mm単位)	33~50 (1mm単位)	33~50 (1mm単位)	10.0~25.0	1,870	2,260	2,430	3,060	
				25.1~50.0	2,660	3,460	3,790	4,450	
				50.1~75.0	3,510	4,710	5,180	6,020	
41~50 (1mm単位)	43~60 (1mm単位)	43~60 (1mm単位)	10.0~25.0	2,260	2,830	3,060	3,820		
			25.1~50.0	3,230	4,380	4,840	5,640		
			50.1~75.0	4,250	5,980	6,610	7,650		
51~60 (1mm単位)	53~70 (1mm単位)	53~70 (1mm単位)	10.0~25.0	2,720	3,500	3,810	4,850		
			25.1~50.0	3,860	5,440	6,060	7,210		
			50.1~75.0	5,070	7,420	8,300	9,770		
					75.1~100.0	6,230	7,850	8,560	11,980

◎ D-Vの加工条件  
4≤D≤10 → V≤D-2  
10.5≤D≤30 → V≤D-4  
31≤D≤60 → V≤D-6

◎ H-D≥2 ◎ T≤L-1 ◎ D/10≤L≤V×8

Order 注文例  
型式 - V - D - H - T - L  
FTCLMB - V10.5 - D20 - H30 - T4 - L23.8

Delivery 出荷日  
●材質S45C ●材質SUS420J2  
3 日目発送 ●ストークA 200円/1本 ●P82 ●ストークB 200円/1本 ●P82  
◎同一サイズ3本以上は一律540円 ◎同一サイズ3本以上は一律540円

Alteration 追加加工  
●並級 型式 - V - D - H - T - L (TCB・TCC・TCD・TCE)  
●精密級 FTCLB - V10.5 - D20 - H30 - T4 - L23.8 - TCB  
●材質S45C・SUS304・S45C(焼入れ品を除きます)・黄銅  
3 日目発送

◎標準タイプは適用不可。◎アルマイト品は適用不可。◎焼入れ品(硬度表記のあるもの)は適用不可。

並級 T公差変更	Alterations			
	Code	TCB	TCC	TCD
	ツバ厚公差(T)を変更 T - 0.1 T - 0.3 指定方法 TCB	ツバ厚公差(T)を変更 T + 0.3 T + 0.1 指定方法 TCC	ツバ厚公差(T)を変更 T - 0 T - 0.2 指定方法 TCD	ツバ厚公差(T)を変更 T + 0.2 T + 0 指定方法 TCE
¥/1Code	100	100	100	100

精密級 T公差変更	Alterations				
	Code	TSA	TSB	TSC	TSD
	ツバ厚公差(T)を変更 T ± 0.025 指定方法 TSA	ツバ厚公差(T)を変更 T - 0.01 T - 0.06 指定方法 TSB	ツバ厚公差(T)を変更 T + 0.06 T + 0.01 指定方法 TSC	ツバ厚公差(T)を変更 T - 0 T - 0.05 指定方法 TSD	ツバ厚公差(T)を変更 T + 0.05 T + 0 指定方法 TSE
¥/1Code	120	120	120	120	120

Alterations	C面取り追加加工 (片側1ヶ所 両側)	タップ穴追加加工	止めネジ穴追加加工 (1ヶ所 2ヶ所)	スリ割り追加加工	内径公差変更																																																																			
	Code	VM (並目) VMA (細目)	MC・WMC	SLC	VKC																																																																			
	C面を追加加工します。 指定方法 CC1.5 WCC2.5	タップ(貫通)を追加加工します。 指定方法 VM4 VM VMAに変わって指定 例: FTCLS-VMA4-D10-H13-T18 ◎ L≤M×8	D部にタップを追加加工します。 指定方法 MC3 WMC5 ◎ 片肉(D-V)/2条件は下表になります。 ◎ 片肉幅は固定になります。 ◎ MC・WMC: 下表より選択	スリットを追加加工します。 指定方法 SLC	内径の公差をH7に変更します。 指定方法 VKC																																																																			
Spec.	◎ CC・WCC=指定0.5mm単位 ◎ CC・WCC<(D-V)/2	<table border="1"> <tr><th>タップ径</th><th>VM</th><th>VMA</th><th>Lmax</th></tr> <tr><td>4</td><td>0.7</td><td>-</td><td>20</td></tr> <tr><td>5</td><td>0.8</td><td>0.5</td><td>30</td></tr> <tr><td>6</td><td>1.0</td><td>0.75</td><td>35</td></tr> <tr><td>8</td><td>1.25</td><td>-</td><td>40</td></tr> <tr><td>10</td><td>1.5</td><td>1.0</td><td>50</td></tr> <tr><td>12</td><td>1.75</td><td>-</td><td>55</td></tr> <tr><td>16</td><td>2.0</td><td>-</td><td>90</td></tr> <tr><td>18</td><td>-</td><td>1.5</td><td>100</td></tr> <tr><td>20</td><td>2.5</td><td>-</td><td>100</td></tr> </table>	タップ径	VM	VMA	Lmax	4	0.7	-	20	5	0.8	0.5	30	6	1.0	0.75	35	8	1.25	-	40	10	1.5	1.0	50	12	1.75	-	55	16	2.0	-	90	18	-	1.5	100	20	2.5	-	100	<table border="1"> <tr><th>タップ径</th><th>MC</th><th>WMC</th></tr> <tr><td>3・4・5・6</td><td>150</td><td>200</td></tr> <tr><td>8・10・12</td><td>200</td><td>300</td></tr> </table>	タップ径	MC	WMC	3・4・5・6	150	200	8・10・12	200	300	<table border="1"> <tr><th>外径D</th><th>SLC (D-V)/2</th></tr> <tr><td>10.0~20.0</td><td>1 5以下</td></tr> <tr><td>20.5~40</td><td>2 10以下</td></tr> <tr><td>41~</td><td>5 20以下</td></tr> </table>	外径D	SLC (D-V)/2	10.0~20.0	1 5以下	20.5~40	2 10以下	41~	5 20以下	<table border="1"> <tr><th>D</th><th>D-V</th></tr> <tr><td>6~10</td><td>D-V≤2</td></tr> <tr><td>10.5~20</td><td>D-V≤3</td></tr> <tr><td>21~30</td><td>D-V≤6</td></tr> <tr><td>31~40</td><td>D-V≤8</td>&lt;/</tr></table>	D	D-V	6~10	D-V≤2	10.5~20	D-V≤3	21~30	D-V≤6	31~40	D-V≤8
タップ径	VM	VMA	Lmax																																																																					
4	0.7	-	20																																																																					
5	0.8	0.5	30																																																																					
6	1.0	0.75	35																																																																					
8	1.25	-	40																																																																					
10	1.5	1.0	50																																																																					
12	1.75	-	55																																																																					
16	2.0	-	90																																																																					
18	-	1.5	100																																																																					
20	2.5	-	100																																																																					
タップ径	MC	WMC																																																																						
3・4・5・6	150	200																																																																						
8・10・12	200	300																																																																						
外径D	SLC (D-V)/2																																																																							
10.0~20.0	1 5以下																																																																							
20.5~40	2 10以下																																																																							
41~	5 20以下																																																																							
D	D-V																																																																							
6~10	D-V≤2																																																																							
10.5~20	D-V≤3																																																																							
21~30	D-V≤6																																																																							
31~40	D-V≤8																																																																							



# 樹脂ワッシャ/カラー 特性と特長

RESIN WASHERS—STANDARD TYPE— RESIN COLLARS—FEMALE THREAD TYPE—

# 樹脂ワッシャ/樹脂カラー

—標準タイプ/寸法フリー指定タイプ— —内ねじタイプ—

**大口注文** **プライスダウン**  
最大40%  
値下げ価格

類似寸法は加工部品Cナビガイドブック：P.17

CADデータフォルダ名：35\_Washers

## 樹脂ワッシャ/カラーの特性・特長

項目	試験方法 (ASTM)	単位	材質									
			MCナイロン				ペークライト		フッ素樹脂 477化エチレン	PEEK ポリエーテル エーテルケトン	エポキシ ガラス	ポリカーボ ネイト
			ポリアセタール	スタンダード	導電性グレード CDR2 CDR6		紙系	布系				
引張強さ	D638	Mpa	61	96	68	74	113	97	13.7~34.3	98	309	59
伸び	D638	%	40	30	10	7	2.6	2	200~400	20	4	60~120
曲げ強さ	層に垂直	D790	89	110	117	117	189	144	—	170	431	80.4
	層に平行	D790					182	148				
曲げ弾性率	D790	Mpa	2589	3530	4110	4020	9680	8650	550	4021	16300	2200
圧縮強さ	D695	Mpa	103	95	98	93	135	116	11.8	119	266	73.5
[5%変形]	D695						132	115				
アイソット衝撃値 (ノッチ付)	D256	J/m	74	50	35	35	—	—	160	77	—	740~980
ロックウェル硬度	D785	R・Mスケール	R119 M78	R120	R119	R117	—	—	—	120	—	M60~70
荷重たわみ (0.45Mpa)	D648	°C	158	215	215	215	—	—	121	—	—	145
温度 (1.82Mpa)	D648	°C	110	200	200	200	206	230~	55	155	230~	—
線膨張率	D696	10 <sup>-5</sup> /°C	9.0	9.0	8.0	7.5	—	—	9.9	5.0	1.55	6.0~7.0
熱伝導率	D177	W/m・k	0.233	0.233	0.512	0.709	0.21	0.38	0.25	0.25	0.47	0.19
誘電率 (106 Hz)	D150	—	3.7	3.7	—	—	4.24	5.33	18.6	3.3	—	3.0
誘電正接 (106 Hz)	D150	—	0.007	0.02	—	—	0.036	0.056	~2×10 <sup>-4</sup>	3×10 <sup>-3</sup>	—	0.0012
体積固有抵抗率	D257	Ω・cm	10 <sup>14</sup>	4.2×10 <sup>13</sup>	10 <sup>2</sup> ~10 <sup>4</sup>	10 <sup>4</sup> ~10 <sup>6</sup>	—	—	>10 <sup>18</sup>	10 <sup>16</sup>	10 <sup>11</sup> ~10 <sup>12</sup>	2×10 <sup>16</sup>
絶縁破壊強さ (貴層破壊電圧)	D149	kV/mm	20	20	—	—	29.5	18.6	19	19	23	15
耐アーク性	D495	sec	—	—	—	—	—	—	>300	23	180	—
比重	D792	—	1.41	1.16	1.2	1.23	1.4	1.4	2.14~2.2	1.32	1.8~1.85	1.2
吸水率 (23°C水中×24h)	D570	%	0.22	0.8	—	—	0.5~1.3	1.6~1.8	<0.01	0.14	0.4	0.24
ガラス繊維含有	—	—	—	—	—	—	—	—	—	—	含有	—
使用雰囲気温度	—	°C	-45~95	-40~120			-50~100	-50~100	-40~250	-50~250	-150~180	~110
食品衛生法	—	—	適合	適合*	適合*	適合*	—	—	適合	適合	—	—
特徴	◎：非常によい	すべり特性	○	○	○	○	△	△	○	○	△	△
	○：よい	断熱性	△	△	△	△	○	○	○	○	△~○	○
	△：わるい	絶縁性	○	○	○	○	○	○	○	○	○	○
	×	耐摩耗性	△	△	△	△	×	×	○	○	×	×
	×	寸法安定性	○	△	△	△	○	○	×	○	○	○
	×	切削性	◎	○	△	△	○	○	○	○	△	○

※食品衛生法適合 (MCナイロン スタンダードは1.5hrs煮沸後、導電性グレードは2hrs煮沸後) 記載数値は代表値であり、保証値ではありません。  
 ※樹脂材料は吸水により寸法変化しますので長期保管は避けください。(特に吸水率の高い材質ほど変形します)  
 ※ポリカーボネイトの特性値はJIS試験での数値です。(参考としてください)

## ワッシャ/カラーのラインアップ

形状 タイプ	材質	ポリアセタール	MCナイロン		ペークライト		フッ素樹脂 477化エチレン	PEEK ポリエーテル エーテルケトン	エポキシ ガラス	ポリカーボ ネイト
			スタンダード	導電性グレード CDR2 CDR6	紙系	布系				
			色	白色 黒色 青色 7色	黒色	茶色 薄茶色				
ワッシャ	標準タイプ	P116 外径 D 4~60 内径 V 0~55 厚さ T 2~10	●	●	●	●	●	●	●	●
	ノーズタイプ	P117 外径 D 6~60 ノーズ径 V 2~58 厚さ T 3~50	●	●	●	●	●	●	●	●
	ツバ付タイプ	P117 外径 D 4~60 ツバ径 H 6~70 内径 V 0~55 全長 L 2~10	●	●	●	●	●	●	●	●
	ザグリ穴タイプ	P118 外径 D 10~60 内径 P 3~53 厚さ T 3~50	●	●	●	●	●	●	●	●
	標準タイプ	P119 外径 D 4~100 内径 V 2~55 全長 L 10~100	●	●	●	●	●	●	●	●
カラー	標準タイプ	P119 外径 D 4~100 内径 V 2~55 全長 L 10~100	●	●	●	●	●	●	●	●
	ツバ付タイプ	P121 外径 D 4~100 ツバ径 H 6~110 内径 V 0~90 全長 L 10~100	●	●	●	●	●	●	●	●

●規格あり —規格なし



Type	材質	色
寸法選択タイプ	ポリアセタール	白 黒
フリー指定タイプ	MCナイロン	青
WSJJ FWSJJ	スタンダードグレード	アイボリー
WSJK FWSJK	MCナイロン	黒
WSJM FWSJM	導電性グレード	紙系
WSJW FWSJW	紙系	茶
WSJD FWSJD	布系	うす茶
WSJT FWSJT	フッ素樹脂	白
WSJB FWSJB	PEEK	灰
WSJN FWSJN	エポキシガラス	緑
WSJF FWSJF		
WSJP FWSJP		
WSJE FWSJE		

材質特性 P.155 左ページ

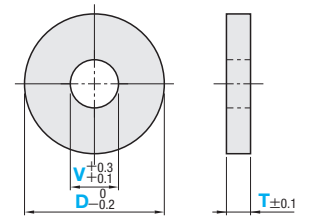

## 寸法選択タイプ

価格表記の無いものは規格がありません。

Type	D	V 選択	T 選択	¥基準単価													
				WSJJ WSJK	WSJM WSJW	WSJD WSJT	WSJB WSJN	WSJF WSJP	WSJE								
4	2		2														
5	2 3		2														
6	2 3 4		2														
8	2 3 4 5 6		2 3 5	70	80	180	170	60	110								
10	2 3 4 5 6 8		2 3 5														
12	3 4 5 6 8 10		2 3 5														
13	4 5 6 8 10		2 3 5														
14	4 5 6 8 10		2 3 5														
15	4 5 6 8 10 12		2 3 5														
16	4 5 6 8 10 12		2 3 5	100	110	250	230	90	140								
20	4 5 6 8 10 12 15 16		2 3 5	110	130	290	260	100	180								
25	6 8 10 12 15 16 20		2 3 5	130	150	340	300	120	180								
30	8 10 12 15 16 20 25		2 3 5	150	170	380	330	140	220								
35	10 12 15 16 20 25		3 5 10	170	180	400	350	160	250								
40	10 12 15 16 20 25 30		3 5 10	180	200	450	400	160	270								
50	10 12 15 16 20 25 30		3 5 10	210	220	490	440	190	360								
60	15 16 20 25 30		3 5 10	250	290	650	—	230	400								

## 寸法フリー指定タイプ

価格表記の無いものは規格がありません。

Type	D	V	T	¥基準単価													
		0.5mm単位 (V寸3以上)	0.5mm単位	FWSJJ FWSJK	FWSJM FWSJW	FWSJD FWSJT	FWSJB FWSJN	FWSJF FWSJP	FWSJE								
4.0~10.0 (0.5mm単位)			2.0~ 5.0	170	190	410	390	170	270	430	870	380					
10.5~20 (0.5mm単位)			2.0~ 5.0	240	280	540	520	190	290	560	1,110	500					
21~30 (1mm単位)		0 (穴加工無し)	2.0~ 5.0	360	440	690	660	280	610	720	1,430	660					
31~40 (1mm単位)		2.0 2.6	2.0~ 5.0	510	570	830	790	310	670	870	1,670	830					
41~50 (1mm単位)		3.0~58.0 (V≦D-2)	2.0~ 5.0	420	450	1,150	1,100	430	880	1,350	2,250	1,270					
51~60 (1mm単位)		58.5~90.0 (V≦D-6)	2.0~ 5.0	570	620	1,560	1,490	590	1,030	1,840	2,710	1,640					
61~80 (1mm単位)			2.0~ 5.0	480	510	1,280	1,220	500	990	2,330	3,000	2,090					
81~100 (1mm単位)			2.0~ 5.0	640	690	1,730	1,650	670	1,270	3,150	4,040	2,910					
			5.5~10	810	900	2,250	—	840	1,290	—	—	—					
			2.0~ 5.0	730	850	2,140	—	750	1,370	—	—	—					
			5.5~10	1,020	1,210	3,020	—	1,060	1,780	—	—	—					
			2.0~ 5.0	1,130	1,370	3,430	—	1,180	2,210	—	—	—					
			5.5~10	1,610	1,930	4,840	—	1,690	2,970	—	—	—					



Type	材質	色
CLJTJ	ポリアセタール	
CLJTM	MCナイロン(スタンダードグレード-青色)	

材質特性 P.115~

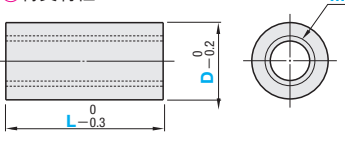

Type	M (×Pitch)	D	L	¥基準単価	
		指定0.5mm単位	CLJTJ	CLJTM	
		10.0~20.0 (0.5mm単位)	540	550	
		25.5~50	880	890	
		10.0~25.0	820	860	
4 (×0.7)		21~30	25.5~50	1,480	1,490
5 (×0.8)		25.5~50	2,020	2,060	
6 (×1.0)		50.5~60	—	—	
8 (×1.25)		10.0~25.0	1,360	1,380	
8A (×1.0)		25.5~50	2,150	2,210	
10 (×1.5)		50.5~60	3,080	3,160	
12 (×1.75)		10.0~25.0	1,550	1,600	
12A (×1.0)		25.5~50	2,180	2,230	
16 (×2.0)		50.5~60	3,190	3,270	
18A (×1.0)		10.0~25.0	1,790	1,850	
20					



RESIN WASHERS-CONVEX TYPE-SHOULDER TYPE-

# 樹脂ワッシャ

—ノーズ付タイプ/ツバ付タイプ—



RESIN WASHERS-COUNTERBORE TYPE-

# 樹脂ワッシャ

—ザグリ穴タイプ—



◎類似寸法は加工部品Cナビガイドブック:P.17  
◎CADデータフォルダ名: 35\_Washers

◎類似寸法は加工部品Cナビガイドブック:P.17  
◎CADデータフォルダ名: 35\_Washers



ノーズ付 寸法選択 寸法フリー指定	ツバ付 寸法フリー指定	材質	色
WNJJ	FWNJ	ポリアセタール	白
—	—	—	黒
WNJM	FWNJM	MCナイロン スタンダードグレード	青
—	—	—	アイボリー
WNJD	FWNJD	MCナイロン 導電性グレード	黒
—	—	—	黒
WNJB	FWNJB	ペークライト	紙系 茶
—	—	—	布系 うす茶
WNJN	FWNJN	フッ素樹脂	白
—	—	—	PEEK
—	—	—	灰
—	—	—	エポキシガラス

◎材質特性 P.115~

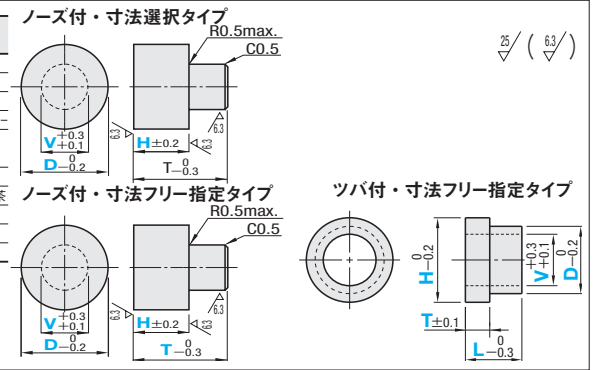

### ノーズ付・寸法選択タイプ

型式 Type	D	V 選択			H 選択	T	¥基準単価								
		3	4	5			WNJJ	WNJM	WNJD	WNJB	WNJN				
6	3	2	3	5	H+3	180	210	470	160	220					
	4	2	3	5	H+4										
8	4	2	3	5	H+5	230	260	580	210	270					
	5	2	3	5	H+5										
10	5	3	5	10	H+8	280	330	740	260	330					
	6	3	5	10	H+10										
12	6	3	5	10	H+10	330	380	850	310	370					
	8	5	10	12	H+15										
15	8	5	10	12	H+15	380	420	940	360	410					
	10	5	10	12	H+15										
20	10	5	10	12	H+15	450	590	1,330	430	560					
	12	5	10	12	H+15										
25	12	5	10	12	H+15	520	660	1,480	500	630					
	15	5	10	12	H+15										
30	15	5	10	12	H+15	640	710	1,600	620	670					
	20	5	10	12	H+20										
40	20	5	10	12	H+20										
	30	5	10	12	H+20										
50	25	5	10	12	H+20										
	30	5	10	12	H+20										
60	30	5	10	12	H+20										
	40	5	10	12	H+20										

### ノーズ付・寸法フリー指定タイプ

型式	D	V 0.5mm単位		H 0.5mm単位	T	¥基準単価											
		FWNJ	FWNJM			FWNJD	FWNJB	FWNJN	FWNJP	FWNJE	FWNJ	FWNJM	FWNJD	FWNJB	FWNJN	FWNJP	FWNJE
6.0~10.0 (0.5mm単位)	2.0~8.0	3.0~10.0	310	330	830	790	270	380	840	1,110	500						
		10.5~20	320	340	850	810	290	390	860	1,440	650						
		20.5~30	410	440	1,110	1,060	390	500	1,120	1,870	840						
10.5~20 (0.5mm単位)	4.0~18.0	3.0~10.0	400	420	1,050	1,000	280	470	1,060	1,270	580						
		10.5~20	420	450	1,130	1,080	350	490	1,140	1,650	750						
		20.5~30	620	640	1,620	1,540	500	730	1,630	2,140	970						
21~30 (1mm単位)	10.0~28.0	3.0~10.0	660	700	1,750	1,670	420	820	1,760	1,670	830						
		10.5~20	680	760	1,900	1,810	540	840	1,910	2,170	1,070						
		20.5~30	1,070	1,170	2,930	2,790	890	1,370	2,940	2,820	1,390						
31~40 (1mm単位)	15.0~38.0	5.0~10.0	890	970	2,430	2,310	840	1,380	2,440	2,710	1,640						
		10.5~20	1,070	1,170	2,930	2,790	900	1,420	2,940	3,520	2,130						
		20.5~30	1,320	1,450	3,630	3,450	1,380	2,340	3,640	4,570	2,760						
41~50 (1mm単位)	20.0~48.0	10.0~20.0	1,040	1,130	1,940	1,850	1,080	2,080	1,950	5,250	3,780						
		20.5~30	1,290	1,430	3,570	3,400	1,260	2,080	3,580	6,820	4,910						
		30.5~40	1,560	1,710	4,300	4,090	1,630	3,150	4,310	8,860	6,380						
51~60 (1mm単位)	30.0~58.0	40.5~50	1,800	1,950	4,870	4,630	1,880	3,390	4,880	11,510	8,290						
		10.0~20.0	1,080	1,180	2,970	—	1,120	2,170	—	—	—						
		20.5~30	1,340	1,460	3,680	—	1,400	2,690	—	—	—						
		30.5~40	1,610	1,760	4,400	—	1,680	3,240	—	—							
		40.5~50	1,830	1,980	4,980	—	1,920	3,490	—	—							

加工条件 ◎V≤D-2 ◎VX≥T-H≥1 ◎V≤2.5→T≤10 ◎V=3.0→T≤20

Order 注文例 型式 - V - H  
WNJ8 - 5 - 5

Delivery 出荷日 3 日目発送 ストック A 200円/1本 数量 P82  
◎同一サイズ3本以上は一律540円

Price 価格 数量スライド価格 (1円未満切り捨て) P81  
数量 1~19 20~49 50~99 100~199 200~400 401以上  
値引率 基準単価 5% 10% 15% 18% 出荷日・価格 共にお見積  
出荷日 通常 +4日

Order 注文例 型式 - D - V - H - T  
FWNJN - D19.5 - V11.5 - H10.5 - T25.0

Delivery 出荷日 3 日目発送 大口 出荷日 +4 日目出荷 数量 200~400  
◎大口 +4 日目出荷 ◎ストック対応なし

Price 価格 数量スライド価格 (1円未満切り捨て) P81  
数量 1~19 20~49 50~99 100~199 200~400 401以上  
値引率 基準単価 5% 10% 15% 18% 出荷日・価格 共にお見積  
出荷日 通常 +4日

### ツバ付・寸法フリー指定タイプ

型式	D	H	V 0.5mm単位 (V寸3以上)	T 0.5mm単位	L 0.5mm単位	¥基準単価														
						FWHJ	FWHJM	FWHJD	FWHJT	FWHJB	FWHJN	FWHJF	FWHJP	FWHJE						
4.0~10.0 (0.5mm単位)	6.0~20 (0.5mm単位)	0	3.0~55.0	1.0~8.0	2.0~5.5	530	600	1,200	1,140	800	830	1,200	1,590	720						
						600	670	1,350	1,290	850	890	1,360	2,280	1,030						
						750	820	1,650	1,570	1,130	1,180	1,660	2,070	940						
10.5~20 (0.5mm単位)	12.5~30 (0.5mm単位)	2.0~5.5	3.0~55.0	1.0~8.0	6.0~10.0	820	900	1,800	1,710	1,200	1,250	1,800	2,160	990						
						980	1,050	2,100	2,000	1,460	1,560	2,110	2,550	1,090						
						1,050	1,120	2,250	2,140	1,600	1,670	2,260	2,970	1,350						
21~30 (1mm単位)	23~40 (1mm単位)	6.0~10.0	3.0~55.0	1.0~8.0	2.0~5.5	1,270	1,430	2,850	2,710	1,860	1,980	2,860	2,710	1,350						
						1,350	1,500	3,000	2,850	2,000	2,120	3,000	3,410	1,680						
						1,570	1,720	3,450	3,280	2,400	2,520	3,460	3,320	1,640						
31~40 (1mm単位)	33~50 (1mm単位)	6.0~10.0	3.0~55.0	1.0~8.0	2.0~5.5	1,650	1,800	3,600	3,420	2,530	2,650	3,600	4,000	2,420						
						1,950	2,100	4,200	—	2,800	2,970	—	—	—						
						2,400	2,550	5,100	—	3,200	3,230	—	—	—						
41~50 (1mm単位)	43~60 (1mm単位)	2.0~5.5	3.0~55.0	1.0~8.0	6.0~10.0															
51~60 (1mm単位)	53~70 (1mm単位)	2.0~5.5	3.0~55.0	1.0~8.0	6.0~10.0															

Order 注文例 型式 - D - H - V - T - L  
FWHJN - D20.0 - H30.0 - V10.5 - T2.5 - L8.5

Delivery 出荷日 3 日目発送 ストック A 200円/1本 数量 P82  
◎同一サイズ3本以上は一律540円

Price 価格 数量スライド価格 (1円未満切り捨て) P81  
数量 1~19 20~29 30~39 40~99  
値引率 基準単価 5% 10% 15% 18% 出荷日・価格 共にお見積  
出荷日 通常 +4日



標準タイプ	寸法フリー指定タイプ	材質	色
WZJJ	FWZJJ	ポリアセタール	白
—	—	—	黒
WZJM	FWZJM	MCナイロン スタンダードグレード	青
—	—	—	アイボリー
WZJD	FWZJD	MCナイロン 導電性グレード	黒
—	—	—	黒
WZJB	FWZJB	ペークライト	紙系 茶
—	—	—	布系 うす茶
WZJN	FWZJN	フッ素樹脂	白
—	—	—	PEEK
—	—	—	灰
—	—	—	エポキシガラス

◎材質特性 P.115~

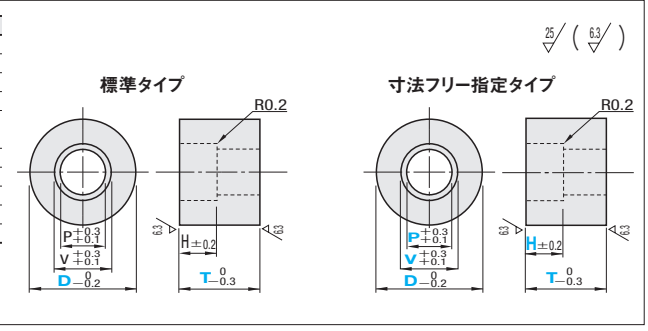

### 標準タイプ

型式 Type	D	T 選択	H	V	P	¥基準単価										
						WZJJ	WZJM	WZJD	WZJB	WZJN						
12	6	8	10	4	6	3.5	180	210	470	160	240					
												5	8	4.5		
14	8	10	12	6	10	5.5	230	250	560	210	350					
												8	11	6.5		
15	10	12	15	8	11	6.5	280	330	740	260	450					
												10	14	9		
30	12	15	18	10	14	9	380	420	940	360	590					
												12	18	11		
40	15	20	24	12	18	11	450	590	1,330	430	760					
												12	18	11		
50	20	25	30	15	20	11	520	660	1,480	500	870					
												12	18	11		
60	25	30	36	20	25	11	640	710	1,600	620	990					
												12	18	11		

### 寸法フリー指定タイプ

型式	D	V 0.5mm単位	P 0.5mm単位	H 0.5mm単位	T 0.5mm単位	¥基準単価														
						FWZJJ	FWZJM	FWZJD	FWZJT	FWZJB	FWZJN	FWZJF	FWZJP	FWZJE						
FWZJJ	10.0~20 (0.5mm単位)	5.0~55.0 (V≤D-2)	3.0~53.0 (P≤V-2)	1.0~48.0 (T-H≤P×8)	3.0~10.0	500	540	1,350	1,080	410	580	1,140	2,090	1,080						
					10.5~20	540	570	1,440	1,160	450	600	1,230	2,250	1,150						
					20.5~30	690	720	1,810	1,460	540	760	1,550	3,980	1,370						



# 樹脂カラー

標準タイプ



類似寸法は加工部品Cナビガイドブック:P.17

CADデータフォルダ名: 35\_Washers



寸法選択タイプ	寸法フリー指定タイプ	材質	色
CLJJ	FCLJJ	ポリアセタール	白
CLJK	FCLJK	MCナイロン	黒
CLJM	FCLJM	スタンダードグレード	青
CLJW	FCLJW	導電性グレード	アイボリー
CLJD	FCLJD	MCナイロン	黒
CLJT	FCLJT	導電性グレード	紙系
CLJB	FCLJB	ペークライト	茶
CLJN	FCLJN	フッ素樹脂	薄茶
CLJF	FCLJF	PEEK	白
CLJP	FCLJP	エポキシガラス	灰
CLJE	FCLJE		緑

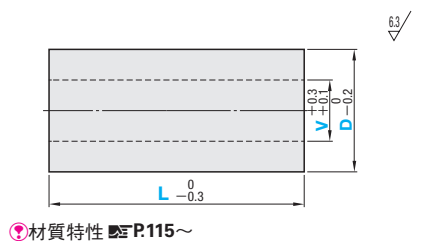

材質特性 P.115~

寸法選択タイプ

Type	V	D 選択	L 0.5mm単位	¥基準単価																			
				CLJJ	CLJK	CLJM	CLJW	CLJD	CLJB	CLJN	CLJT	CLJF	CLJP	CLJE									
CLJJ CLJK CLJM CLJW CLJD CLJT CLJB CLJN CLJF CLJP CLJE	2	(4) 5 6 8 10 11 12	(4) ...V2のみ	10.0~25.0	170	190	400	160	250	380	530	1,220	380	25.5~30.0	200	220	470	190	370	450	690	1,730	470
	3	(6) 8 10 11 12 13 14 15 16 20	(6) ...V4のみ	10.0~25.0	170	190	400	160	250	380	1,200	2,420	510	25.5~50.0	200	220	470	190	370	450	1,470	4,130	600
	4	8 10 11 12 13 14 15 16 20 25		10.0~25.0	180	210	450	170	360	430	1,560	3,270	1,270	25.5~50.0	220	250	550	210	400	520	1,980	5,510	1,490
	6	10 11 12 13 14 15 16 20 25 30		10.0~25.0	220	240	510	210	390	480	2,090	3,640	1,650	25.5~50.0	250	280	600	240	430	570	2,420	6,040	1,850
	8	12 13 14 15 16 20 25 30		10.0~25.0	290	340	710	280	490	670	2,840	7,790	2,030	25.5~50.0	290	340	710	280	490	670	2,840	7,790	2,030
	10	12 13 14 15 16 20 25 30		10.0~25.0	340	380	790	330	530	750	3,790	10,520	2,340	25.5~50.0	340	380	790	330	530	750	3,790	10,520	2,340
	12	15 16 20 25 30		10.0~25.0	420	450	700	410	600	670	5,040	11,210	3,260	25.5~50.0	420	450	700	410	600	670	5,040	11,210	3,260
	15	20 25 30		10.0~25.0	590	630	780	580	740	6,070	13,520	3,930	25.5~50.0	590	630	780	580	740	6,070	13,520	3,930	35 40 50	
	16	35 40 50		10.0~25.0	680	760	880	670	910	840	6,940	15,450	4,490	25.5~50.0	680	760	880	670	910	840	6,940	15,450	4,490
	20	(25) 30 (25) ...V20のみ		10.0~25.0	280	310	610	270	490	580	3,850	8,560	2,490	25.5~50.0	280	310	610	270	490	580	3,850	8,560	2,490
	25	35 40 50		10.0~25.0	600	640	850	580	810	7,050	15,690	4,560	25.5~50.0	600	640	850	580	810	7,050	15,690	4,560	60	
	30	40 50		10.0~25.0	850	910	1,010	840	960	9,100	20,280	5,900	25.5~50.0	850	910	1,010	840	960	9,100	20,280	5,900	60	

寸法フリー指定タイプ

型式	V	D	L	¥基準単価																			
				FCLJJ	FCLJK	FCLJM	FCLJW	FCLJD	FCLJB	FCLJN	FCLJT	FCLJF	FCLJP	FCLJE									
FCLJJ FCLJK FCLJM FCLJW FCLJD FCLJT FCLJB FCLJN FCLJF FCLJP FCLJE	0 (穴加工無し)	4.0~10.0 (0.5mm単位)	D≤5...L≤50	10.0~25.0	260	270	680	210	290	510	700	1,390	470	25.5~50.0	320	350	880	270	360	650	930	1,850	570
				50.5~75.0	420	450	1,130	360	460	840	1,530	2,370	1,200	75.5~100.0	550	570	1,440	430	620	1,050	1,950	3,030	1,520
		10.5~20.0 (0.5mm単位)	D≤5...L≤50	10.0~25.0	340	370	940	250	380	690	990	2,000	890	25.5~50.0	500	540	1,350	360	570	980	1,430	3,180	1,290
				50.5~75.0	660	720	1,800	500	740	1,310	1,900	4,650	1,710	75.5~100.0	860	930	2,340	670	970	1,710	2,470	6,650	2,220
		21~30 (1mm単位)	D≤5...L≤50	10.0~25.0	590	660	1,660	450	700	1,220	1,750	3,250	1,570	25.5~50.0	1,020	1,110	2,780	730	1,160	2,040	2,930	5,990	2,400
				50.5~75.0	1,350	1,490	3,740	990	1,610	2,730	3,940	8,860	2,600	75.5~100.0	1,710	1,860	4,660	1,340	2,160	3,400	4,910	12,150	2,950
	3.0~55.0 (0.5mm単位)	D≤50.0 ...V≤D-2	31~40 (1mm単位)	10.0~25.0	1,130	1,160	2,900	770	1,230	2,110	3,060	4,510	1,960	25.5~50.0	1,630	1,800	4,490	1,270	2,050	3,270	4,730	8,020	3,030
				50.5~75.0	2,320	2,540	6,370	1,810	2,970	4,640	6,710	12,510	4,300	75.5~100.0	2,660	2,920	7,300	2,410	3,960	5,310	7,690	15,770	4,930
	D≥50.5 ...V≤D-6	D≥50.5 ...V≤D-6	41~50 (1mm単位)	10.0~25.0	1,250	1,360	3,420	1,130	1,830	2,490	4,320	6,090	2,870	25.5~50.0	1,650	1,800	4,530	1,730	3,170	3,310	5,730	9,280	3,810
				50.5~75.0	2,410	2,650	6,620	2,520	4,580	4,820	8,370	14,920	5,570	75.5~100.0	2,780	3,050	7,630	2,910	5,320	5,560	9,650	18,930	6,420
	51~60 (1mm単位)	D≥50.5 ...V≤D-6	51~60 (1mm単位)	10.0~25.0	1,460	1,610	4,020	1,530	2,350	—	—	—	—	25.5~50.0	1,880	2,070	5,170	1,980	3,610	—	—	—	—
				50.5~75.0	2,690	2,960	7,390	2,820	5,170	—	—	—	—	—	75.5~100.0	3,000	3,300	8,250	3,140	5,750	—	—	—
0 (穴加工無し)	D≤50.0 ...V≤D-6	61~80 (1mm単位)	10.0~25.0	2,250	2,560	6,410	2,340	4,410	—	—	—	—	25.5~50.0	3,590	4,280	10,710	3,760	7,110	—	—	—	—	
			50.5~75.0	5,140	5,980	14,960	5,390	10,170	—	—	—	—	—	75.5~100.0	5,980	6,870	17,190	6,270	11,440	—	—	—	—
3.0~90.0 (0.5mm単位)	D≤50.0 ...V≤D-6	81~100 (1mm単位)	10.0~25.0	3,240	3,610	9,040	3,400	6,410	—	—	—	—	25.5~50.0	4,790	5,710	14,280	5,030	9,480	—	—	—	—	
			50.5~75.0	6,380	7,350	18,380	6,650	12,540	—	—	—	—	—	75.5~100.0	7,880	8,910	22,300	8,250	15,530	—	—	—	—

加工条件 L≤V×8

価格表記の無いものは規格がありません。

Order 注文例: 型式 - V - D - L  
FCLJB - V20.0 - D30 - L18.5

Delivery 出荷日: 3 日目発送

大 口 出荷日 +4 日目出荷

数量 100~200

Alteration 追加加工

●寸法選択タイプ  
型式 - D - L - (CC・WCC・AC...etc.)  
CLJJ12 - 30 - 45 - AC10 - Q15

●寸法フリー指定タイプ  
型式 - V (VM・VMA) - D - L - (CC・WCC・AC...etc.)  
FCLJP - VM10 - D35 - L60 - CC25

●数量スライド価格 (1円未満切り捨て) P.81

数量	1~9	10~29	30~49	50~99	100~200	201以上
値引率	基準単価	5%	10%	15%	18%	出荷日・価格
出荷日	通常	通常	通常	通常	+4日	共にお見積

●201以上お見積りになります。

追加加工は、D10以上より適用となります。材質: ペークライト・エポキシガラス・フッ素樹脂には適用できません。

Alterations	C面取り追加加工 (片側1ヶ所 両側)	テーパ追加加工 (片側1ヶ所 両側)	タップ穴追加加工	止めネジ穴追加加工 (1ヶ所 2ヶ所)	スリ割り追加加工
	Spec.	CC・WCC C面を追加加工します。 [指定方法] CC1.5 WCC2.5	AC・WAC テーパを追加加工します。 [指定方法] AC3.5~Q60 WAC5.0~Q30	VM (並目) VMA (細目) タップ(貫通)を追加加工します。 [指定方法] VM4 VMA4 例: FCLJJ-VMA4-D10-L18 ●タップ径と全長(L)の加工限界は下表。 タップ径≤D/2	MC・WMC D部にタップ(並目)を追加加工します。 [指定方法] MC3 WMC5
¥/1Code	CC 100 WCC 200	AC 200 WAC 400	タップ径 VM・VMA 4 0.7 20 5 0.8 30 6 1.0 35 8 1.25 45 10 1.5 60 12 1.75 70 16 2.0 90 18 - 1.5 100 20 2.5 100	タップ径 MC WMC 3・4・5・6 100 150 8・10・12 200 200	150

# 樹脂カラー

ツバ付タイプ



類似寸法は加工部品Cナビガイドブック：P.17

CADデータフォルダ名：35\_Washers

RoHS

寸法選択タイプ	寸法フリー指定タイプ	材質	色
CLJHJ	FCLJHJ	ポリアセタール	白
CLJHK	FCLJHK		黒
CLJHM	FCLJHM	MCナイロン	青
CLJHW	FCLJHW	スタンダードグレード	アイボリー
CLJHD	FCLJHD	MCナイロン	黒
CLJHT	FCLJHT	導電性グレード	黒
CLJHB	FCLJHB	ベークライト	紙系 茶
CLJHN	FCLJHN		薄茶
CLJHF	FCLJHF	フッ素樹脂	白
CLJHP	FCLJHP	PEEK	灰
CLJHE	FCLJHE	エポキシガラス	緑

寸法選択タイプ

寸法フリー指定タイプ

材質特性 P.115~

■寸法選択タイプ		¥基準単価											
型式	D 選択	L 0.5mm単位	CLJHJ	CLJHK	CLJHM	CLJHW	CLJHD	CLJHT	CLJHB	CLJHN	CLJHF	CLJHP	CLJHE
Type	V												
	3	(4) 5 6 8 10	10.0~25.0	290	320	760	270	520	760	1,500	4,000	1,150	
CLJHJ	4	(6) 8 10 11 12 13 14 15 16 20 25	10.0~25.0	290	320	790	270	520	820	3,330	8,500	1,430	
	5	8 10 11 12 13 14 15 16 20 25	25.5~50.0	320	340	840	300	540	890	6,770	12,470	2,930	
CLJHK	6	10 11 12 13 14 15 16 20 25 30	10.0~25.0	320	340	820	300	540	820	3,330	8,500	1,780	
	8	12 13 14 15 16 20 25 30	25.5~50.0	340	370	890	320	570	890	6,770	12,470	3,420	
CLJHM	10	15 16 20 25 30	10.0~25.0	360	390	930	340	590	930	4,480	9,830	2,770	
	12	20 25 30	25.5~50.0	390	410	990	370	610	990	8,670	14,620	5,230	
CLJHW	15	35 40 50	50.5~75.0	420	460	1,100	400	660	1,100				
	16	40 50	75.5~100.0	510	550	1,310	490	750	1,310				
CLJHD	20	50 60	10.0~25.0	400	430	960	380	630	960	4,620	10,130	2,860	
	25	60	25.5~50.0	560	580	1,030	540	780	1,030	8,940	15,060	5,390	
CLJHT	30	75 80	50.5~75.0	630	680	1,140	610	880	1,140				
	35	80 90	75.5~100.0	760	850	1,360	740	1,050	1,360				
CLJHB	40	90 100	10.0~25.0	490	530	1,030	470	780	1,030	7,300	15,380	5,180	
	45	100 110	25.5~50.0	850	880	1,390	820	1,180	1,390	9,800	20,600	6,700	
CLJHN	50	120 130	50.5~75.0	1,010	1,090	1,620	980	1,410	1,620				
	55	130 140	75.5~100.0	1,280	1,430	2,030	1,240	1,770	2,030				
CLJHF	60	150 160	10.0~25.0	460	490	1,000	440	690	1,000	4,760	10,440	2,950	
	65	160 170	25.5~50.0	620	650	1,060	600	850	1,060	9,210	15,520	5,560	
CLJHP	70	180 190	50.5~75.0	760	800	1,180	740	1,000	1,180				
	75	190 200	75.5~100.0	930	1,020	1,410	910	1,220	1,410				
CLJHE	80	200 210	10.0~25.0	520	550	1,150	490	770	1,150	8,050	16,250	5,700	
	85	210 220	25.5~50.0	900	940	1,570	870	1,230	1,570	10,480	21,720	7,270	
20	90	220 230	50.5~75.0	1,070	1,130	1,920	1,050	1,410	1,920				
	95	230 240	75.5~100.0	1,350	1,480	2,380	1,320	1,770	2,380				
25	100	240 250	10.0~25.0	510	530	1,050	490	730	1,050	5,000	10,970	3,100	
	105	250 260	25.5~50.0	680	730	1,120	660	930	1,120	9,680	16,300	5,840	
30	110	260 270	50.5~75.0	850	930	1,240	830	1,130	1,240				
	115	270 280	75.5~100.0	1,060	1,140	1,480	1,040	1,340	1,480				
35	120	280 290	10.0~25.0	550	570	1,270	530	790	1,270	8,550	17,000	6,120	
	125	290 300	25.5~50.0	950	1,020	1,750	920	1,300	1,750	11,050	22,550	7,620	
40	130	300 310	50.5~75.0	1,130	1,240	2,220	1,110	1,510	2,220				
	135	310 320	75.5~100.0	1,420	1,530	2,720	1,400	1,800	2,720				
45	140	320 330	10.0~25.0	580	600	1,330	560	830					
	145	330 340	25.5~50.0	1,000	1,070	1,830	970	1,360					
50	150	340 350	50.5~75.0	1,190	1,310	2,330	1,170	1,600					
	155	350 360	75.5~100.0	1,500	1,620	2,850	1,480	1,910					
55	160	360 370	10.0~25.0	630	660	1,110	610	860	1,110	5,250	11,520	3,260	
	165	370 380	25.5~50.0	800	930	1,180	780	1,130	1,180	10,170	17,120	6,140	
60	170	380 390	50.5~75.0	970	1,060	1,310	950	1,260	1,310				
	175	390 400	75.5~100.0	1,190	1,310	1,560	1,170	1,510	1,560				
65	180	400 410	10.0~25.0	580	610	1,690	560	790	1,690	18,570	17,680	7,100	
	185	410 420	25.5~50.0	1,000	1,160	2,340	970	1,410	2,340	24,470	23,380	8,830	
70	190	420 430	50.5~75.0	1,190	1,300	2,620	1,170	1,550	2,620				
	195	430 440	75.5~100.0	1,500	1,650	3,230	1,470	1,900	3,230				
75	200	440 450	10.0~25.0	610	640	1,770	590	830					
	205	450 460	25.5~50.0	1,060	1,230	2,450	1,030	1,500					
80	210	460 470	50.5~75.0	1,250	1,370	2,750	1,230	1,630					
	215	470 480	75.5~100.0	1,580	1,740	3,390	1,550	2,000					
85	220	480 490	10.0~25.0	610	640	1,810	590	830	1,810	19,820	18,570	7,620	
	225	490 500	25.5~50.0	1,050	1,220	2,430	1,020	1,490	2,430	26,050	24,470	9,420	
90	230	500 510	50.5~75.0	1,250	1,370	2,720	1,230	1,630	2,720				
	235	510 520	75.5~100.0	1,580	1,740	3,330	1,550	2,000	3,330				
95	240	520 530	10.0~25.0	650	680	1,900	590	880					
	245	530 540	25.5~50.0	1,120	1,300	2,550	1,020	1,590					
100	250	540 550	50.5~75.0	1,320	1,450	2,850	1,230	1,730					
	255	550 560	75.5~100.0	1,660	1,830	3,500	1,550	2,100					

Order 注文例

型式 - D - L

CLJHM10 - 16 - 20

Delivery 出荷日

3 日目発送

ストーク A 200円/1本

大口出荷日 +4 日目出荷 数量 100~200

数量スライド価格 (1円未満切り捨て) P.81

数量	1~9	10~29	30~49	50~99	100~200	201以上
値引率	標準単価	5%	10%	15%	18%	出荷日・価格
出荷日	通常	+	+	+	+	共にお見積

価格表記の無いものは規格がありません。

型式	V	D	H	T	L	¥基準単価									
						FCLJHJ	FCLJHK	FCLJHM	FCLJHW	FCLJHD	FCLJHT	FCLJHB	FCLJHN	FCLJHF	FCLJHP
FCLJHJ	0	4.0~10.0	6.0~20.0	1mm単位	0.5mm単位	10.0~25.0	650	720	1,270	1,200	590	920	1,190	2,400	1,100
						25.5~50.0	910	990	1,770	1,670	820	1,290	1,720	3,820	1,700
FCLJHK	2.0	10.5~20.0	12.5~30.0	1mm単位	0.5mm単位	10.0~25.0	920	1,010	1,790	1,690	820	1,310	2,100	3,900	1,950
						25.5~50.0	1,340	1,460	2,610	2,460	1,200	1,900	3,520	7,190	2,940
FCLJHM	2.6	21~30	23~40	1mm単位	0.5mm単位	10.0~25.0	1,210	1,330	2,370	2,230	1,090	1,720	3,670	5,410	3,380
						25.5~50.0	1,770	1,950	3,440	3,240	1,590	2,520	5,680	9,620	5,330
FCLJHW	3.0~58.0	31~40	33~50	1mm単位	0.5mm単位	10.0~25.0	2,320	2,550	4,510	4,240	2,080	3,320			
						25.5~50.0	2,880	3,160	5,590	5,260	2,580	4,110			
FCLJHD	10.0 ≤ L ≤ 50.0	41~50	43~60	1mm単位	0.5mm単位	10.0~25.0	1,530	1,690	3,000	2,820	1,380	2,200	4,320	6,100	4,050
						25.5~50.0	2,250	2,470	4,370	4,110	2,010	3,200	5,720	9,290	5,600
FCLJHT	50.5 ≤ L ≤ 100	51~60	53~70	1mm単位	0.5mm単位	10.0~25.0	2,960	3,240	5,730	5,390	2,660	4,210			
						25.5~50.0	3,660	4,030	7,110	6,690	3,290	5,220			
FCLJHB	58.5~90.0	61~80	63~90	1mm単位	0.5mm単位	10.0~25.0	1,900	2,090	5,230	3,820	1,710	2,710	5,180	7,320	5,050
						25.5~50.0	2,780	3,050	7,630	5,560	2,490	3,970	6,860	11,150	6,700
FCLJHN	V ≤ D-6	81~100	83~110	1mm単位	1mm単位	10.0~25.0	3,640	4,000	10,000	7,270	3,270	5,210			
						25.5~50.0	4,500	4,950	12,380	9,020	4,040	6,420			
FCLJHF	L ≤ V × 8	10.0~25.0	10.0~25.0	1mm単位											



# セラミックス ワッシャ/シート/カラー

●類似寸法は加工部品Cナビガイドブック：P.35

●CADデータフォルダ名：35\_Washers

RoHS

Type	材質	材質	
ワッシャ	SCERAW CERAW	セラミックス	アルミナ96
ツバ付カラー	CERAB		アルミナ92
カラー	CERAC	セラミックファイバー	
シート	SWSCE		

\*セラミックス(CERAB)のD寸法はV寸に対して固定になります。

ワッシャ・シート

ワッシャ:  $D_{-0.05}$   
シート:  $D_{\pm 0.1}$

カラー

カラー:  $L_{\pm 0.05}$

ツバ付カラー

ツバ付カラー:  $H_{-0.2}$ ,  $L_{-0.1}$ ,  $T_{\pm 0.1}$

# 断熱材ワッシャ/カラー

●類似寸法は加工部品Cナビガイドブック：P.17

●CADデータフォルダ名：35\_Washers

RoHS

材質	断熱材
ワッシャ	DJW
カラー	DJC
ツバ付カラー	DJB

ワッシャ

ワッシャ:  $D_{-0.2}$ ,  $T_{\pm 0.1}$

カラー

カラー:  $L_{-0.3}$ ,  $V_{+0.1}$ ,  $D_{-0.2}$

ツバ付カラー

ツバ付カラー:  $H_{-0.2}$ ,  $L_{-0.3}$ ,  $T_{\pm 0.1}$

■ワッシャ (アルミナ92)

型式	Type	D	V	T	¥基準単価
CERAW10	10	3	3	3	300
CERAW12	12	4	4	3	320
CERAW15	15	5	5	3	330
CERAW20	20	6	6	3	410
CERAW25	25	8	8	3	440
CERAW30	30	10	10	3	480
CERAW35	35	12	12	5	1,050
CERAW40	40	16	16	5	1,610
CERAW45	45	20	20	5	1,680

■ツバ付カラー (アルミナ92)

型式	Type	V	L	H	D	¥基準単価
CERAB6	3	4	8 10 15	10 6	6	400
CERAB8	4	5	8 10 15	12 8	8	410
CERAB10	5	6	8 10 15	15 10	10	440
CERAB12	6	8	8 10 15	20 10	10	520
CERAB16	10	10	10 15 20	25 12	12	640
CERAB20	12	12	10 15 20	30 14	14	780
CERAB25	16	15	15 20 25	35 20	20	1,610
CERAB30	20	20	15 20 25	40 20	20	1,760
CERAB40	25	25	15 20 25	45 25	25	2,070

■カラー (アルミナ92)

型式	Type	V	L	D	¥基準単価
CERAC6	3	4	5~50	6	420
CERAC8	4	5	5~50	8	750
CERAC10	5	6	5~50	10	990
CERAC12	6	8	5~50	10	1,310
CERAC14	8	10	5~50	12	1,800
CERAC16	10	12	5~50	14	2,290
CERAC20	12	16	5~100	20	2,450
CERAC25	16	20	5~100	20	2,610
CERAC30	20	25	5~100	20	2,930
CERAC40	25	30	5~100	25	3,260
CERAC50	30	40	5~100	25	4,610
CERAC60	40	50	5~100	30	6,140

Order 注文例: CERAW10

Delivery 出荷日: 在庫品 翌日出荷 P81

Price 価格: 数量スライド価格 (1円未満切り捨て) P81

数量	1~9	10~49	50~99	100~199
値引率	5%	10%	15%	15%

Order 注文例: CERAB6 - 10

Delivery 出荷日: 在庫品 翌日出荷 P81

Price 価格: 数量スライド価格 (1円未満切り捨て) P81

数量	1~9	10~19	20~49	50~99
値引率	5%	10%	15%	15%

Order 注文例: CERAC16 - 55

Delivery 出荷日: 5 日発送

Price 価格: 数量スライド価格 (1円未満切り捨て) P81

数量	1~9	10~14	15~19	20~49
値引率	5%	10%	15%	15%

■ワッシャ (アルミナ96)

型式	Type	D	V	T	¥基準単価
SCERAW10	10	3 4 5	3	3	300
SCERAW12	12	4 5 6	4	3	320
SCERAW15	15	5 6 8	5	3	330
SCERAW20	20	6 8	6	3	410

■シート (セラミックファイバー)

型式	Type	D	V	T	¥基準単価
SWSCE8	8	3 4	1	1	140
SWSCE10	10	4 5 6	1	1	170
SWSCE12	12	4 5 6 8	1	1	200
SWSCE15	15	5 6 8 10	1	1	240
SWSCE20	20	6 8 10 12	1	1	290
SWSCE25	25	8 10 12 15	1	1	320
SWSCE30	30	8 10 12 15 20	1	1	390

Order 注文例: SCERAW10 - 5

Delivery 出荷日: 在庫品 翌日出荷 P81

Price 価格: 数量スライド価格 (1円未満切り捨て) P81

数量	1~9	10~19	20~49	50~99
値引率	5%	10%	15%	15%

Order 注文例: SWSCE10 - 4 - 1

Delivery 出荷日: 3 日発送

Price 価格: 数量スライド価格 (1円未満切り捨て) P81

数量	1~19	20~49	50~99	100~199
値引率	5%	10%	15%	15%

■アルミナ92・96・セラミックファイバーの特性 (参考: 表中は素材のデータ値です。)

特性	物質名	アルミナ92	アルミナ96	セラミックファイバー
貫層破壊電圧	KV/mm	~10	10	-
体積抵抗力	$\Omega$ -cm	~10 <sup>14</sup>	~10 <sup>14</sup>	-
曲げ強さ	KN/cm <sup>2</sup>	24~34	33	-
圧縮強さ	KN/cm <sup>2</sup>	147~245	210	-
引張強さ	Mpa	1000~1200	1500	0.6
膨張率	1/°C	8×10 <sup>-6</sup>	7.6×10 <sup>-6</sup>	-
熱伝導率	cal/cm・sec・°C	3.6~5.0×10 <sup>-2</sup>	5.0×10 <sup>-2</sup>	1.7×10 <sup>-4</sup>
耐熱性	°C	1000~1200	1500	1300
吸水率	%	0	0	-
比重	-	3.7	3.8	0.25
主材料	-	Al <sub>2</sub> O <sub>3</sub> (92%)	Al <sub>2</sub> O <sub>3</sub> (96%)	-

■ワッシャ (断熱材)

型式	Type	D	V	T	¥基準単価
DJW10	10	3 4 5	3 5	3 5	490
DJW12	12	4 5 6	3 5	3 5	550
DJW16	16	5 6 8	3 5	3 5	630
DJW20	20	5 6 8	3 5	3 5	730
DJW25	25	5	5	5	840

■カラー (断熱材)

型式	Type	V	L	¥基準単価
DJC8	8	3 4 5	10	720, 1,350
DJC10	10	4 5 6	10	840, 1,650
DJC12	12	4 5 6 8	30	900, 1,950
DJC16	16	5 6 8	30	1,320, 3,450
DJC20	20	5 6 8 10	30	1,680, 3,900

■積層方向について  
ワッシャとカラーでは積層方向が異なります(下図)。そのため機械的強度が積層方向により異なります。詳細技術データはP.115をご参照ください。

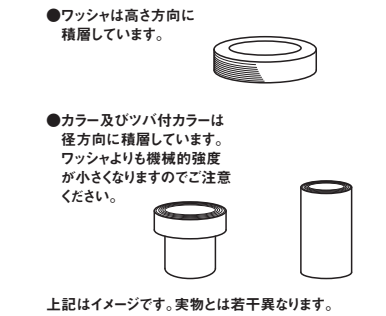

Order 注文例: DJW10 - 3 - 5

Delivery 出荷日: 在庫品 翌日出荷 P81

Price 価格: 数量スライド価格 (1円未満切り捨て) P81

数量	1~9	10~14	15~19	20~49
値引率	5%	10%	15%	15%

Order 注文例: DJC8 - 3 - 10

Delivery 出荷日: 在庫品 翌日出荷 P81

Price 価格: 数量スライド価格 (1円未満切り捨て) P81

数量	1~9	10~14	15~19	20~49
値引率	5%	10%	15%	15%

■ツバ付カラー (断熱材)

型式	Type	V	D	L	H	¥基準単価
DJB4	3	8	10	12	1,920	-
DJB4	4	8 10	10 15	14	2,160	2,400
DJB4	5	10 12	10 15 20	15	2,280	2,520
DJB4	6	10 12	10 15 20	20	2,880	3,120
DJB4	8	12	10 15 20	25	3,360	3,600
DJB4	10	20	10 15 20	30	4,200	4,680

■断熱材の特性 (数値は参考値であり保証値ではありません。)

機械的性質等		熱的・電気的性質等		
引張強さ	Mpa	108	荷重たわみ温度 (1.82Mpa) °C	400~
伸び	%	0.7	線膨張率	10~5/°C
曲げ強さ	層に垂直	145~130 <sup>*1</sup>	熱伝導率	W/m・K
	層に平行	145~130 <sup>*1</sup>	誘電率 (106 Hz)	3.8
曲げ弾性率	MPa	17900	誘電正接 (106 Hz)	0.005
圧縮強さ	層に垂直	439~410 <sup>*1</sup>	体積抵抗率	$\Omega$ ・cm
	層に平行	98~90 <sup>*1</sup>	絶縁破壊強さ (貫層破壊電圧)	KV/mm
アイゾット衝撃値 (ノッチ付)	J/m	29	耐アーク性	sec
ロックウェル硬度	R	R113	吸水率 (23°C水中×24h)	%
ガラス繊維含有	-	有	使用雰囲気温度	°C
比重	-	2.0		~400

Order 注文例: DJB4 - 8 - 15

Delivery 出荷日: 在庫品 翌日出荷 P81

Price 価格: 数量スライド価格 (1円未満切り捨て) P81

数量	1~9	10~14	15~19	20~49
値引率	5%	10%	15%	15%

\*1 400°Cの雰囲気中温度でもMin値を保ちます。  
\*2 2.6(常温~200°C) 3.5(常温~400°C)の値です。

35  
ワッシャ  
カラー・シム



類似寸法は加工部品Cナビガイドブック：P.17

CADデータフォルダ名：35\_Washers

CADデータフォルダ名：35\_Washers

RoHS

ワッシャ	カラー	ツバ付カラー	材質
EPOW	EPOC	EPOB	エポキシガラス
PTW	PTC	PTB	ふっ素樹脂(フッ化エチレン)
PKW	PKC	PKB	PEEK

6.3

ワッシャ

V: +0.3/-0.1, D: 0/-0.2, T: ±0.1

カラー

L: 0/-0.3, V: +0.3/-0.1, D: 0/-0.2

ツバ付カラー

H: 0/-0.2, T: ±0.1, L: 0/-0.3, V: +0.3/-0.1, D: 0/-0.2

材質特性 P.115

■ワッシャ

型式 Type	D	V 選択					T	¥基準単価		
		EPOW	PTW	PKW						
EPOW PTW PKW	10	3	4	5	6	3	190	220	450	
	12	4	5	6	8	3	210	250	500	
	14	4	5	6	8	10	220	290	600	
	15	4	5	6	8	10	220	310	610	
	16	5	6	8	10	3	240	320	630	
	20	5	6	8	10	12	270	410	720	
	25	6	8	10	12	3	280	490	900	
	30	10	12	16	5	320	540	1,080		
	35	12	16	5	410	560	1,620			
	40	16	5	520	630	2,160				

Order 注文例: 型式 - V  
PTW10 - 3

Delivery 出荷日: 在庫品 翌日出荷 P.81

Price 価格: 希望によりPM5:00迄、当日出荷受付致します。

■数量スライド価格 (1円未満切り捨て) P.81

数量	1~49	50~69	70~99	100~199
値引率	基準単価	5%	10%	15%

表示数量超えはお見積り

■カラー

型式 Type	V	D 選択					L 指定1mm単位		
EPOC PTC PKC	2	5	6	8	10	5~30			
	3	5	6	8	10	12	14		
	4	6	8	10	12	14	15		
	5	8	10	12	14	15	16	20	
	6	8	10	12	14	15	16	20	25
	8	12	14	15	16	20	25	30	
	10	14	15	16	20	25	30		
	12	20	25	30	5~100				
	16	20	25	30					
	20	25	30						

Order 注文例: 型式 - D - L  
EPOC16 - 25 - 55

Delivery 出荷日: 3 日目発送

Price 価格: ストック A 200円/1本 P.82

■数量スライド価格 (1円未満切り捨て) P.81

数量	1~9	10~14	15~19	20~49
値引率	基準単価	5%	10%	15%

表示数量超えはお見積り

加工条件 PTCのみL≤D×3

型式 Type	V	¥基準単価											
		EPOC				PTC				PKC			
		L5~25	L26~50	L51~75	L76~100	L5~25	L26~50	L51~75	L76~100	L5~25	L26~50	L51~75	L76~100
EPOC PTC PKC	2	300	360			410	540			950	1,350		
	3	300	360			410	540			1,050	1,500		
	4	530	590			540	740			1,350	2,160		
	5	710	940			880	1,150			1,890	3,240		
	6	940	1,170			1,150	1,550			2,570	4,320		
	8	1,290	1,650			1,350	1,890			2,840	4,730		
	10	1,650	1,760			1,620	2,300			3,240	5,400		
	12	1,760	1,870	2,030	2,350	1,960	2,770	4,050	5,340	3,650	6,080	8,780	12,150
	16	1,870	2,110	2,270	2,590	2,430	3,310	4,730	5,540	4,050	6,750	9,450	12,830
	20	2,110	2,340	2,510	2,830	2,970	3,920	5,400	6,480	4,730	7,430	10,130	13,500

■ツバ付カラー

型式 Type	V	L 選択				H	D	T	¥基準単価		
		EPOB	PTB	PKB							
EPOB PTB PKB	3	8	10	15	20	10	6	5	290	630	1,710
	4	10	12	8	300	720	2,070				
	5	15	10	310	900	2,430					
	6	20	10	360	1,170	3,150					
	8	25	12	450	1,530	4,320					
	10	30	14	560	1,800	5,400					
	12	35	20	1,220	2,340	5,940					
16	40	20	1,340	2,880	8,280						

Order 注文例: 型式 - L  
PKB10 - 10

Delivery 出荷日: 在庫品 翌日出荷 P.81

Price 価格: 希望によりPM5:00迄、当日出荷受付致します。

■数量スライド価格 (1円未満切り捨て) P.81

数量	1~9	10~14	15~19	20~49
値引率	基準単価	5%	10%	15%

表示数量超えはお見積り

RoHS

Type	Type			材質	色	厚さ(T)公差				
	定型リング	定型パック	シート定尺			0.1	0.2	0.3	0.5	1
SWSJJ	PACK-SWSJJ	CIRAJ	ポリアセタール	白	—	±0.03	±0.04	±0.07	±0.10	
SWSPT	PACK-SWSPT	CIRAT	フッ素樹脂	白	—	±0.01	±0.02	±0.03	±0.05	±0.10
SWSPP	PACK-SWSPP	CIRAP	ポリカーボネイト	透明	—	±0.01	±0.02	±0.03	±0.05	±0.10

6.3

■定型リングタイプ

V: +0.5/0, D: 0/-0.5, T: ±0.1

■シート定尺タイプ

A: ±0.5, B: ±0.5, T: ±0.1

■定型リングタイプ・単品販売

型式 Type	D	V 選択					T	¥基準単価				
		SWSJJ	PACK-SWSJJ	SWSPT	PACK-SWSPT	SWSPP		PACK-SWSPP				
SWSJJ SWSPT SWSPP	8	0	3	4	3	140	120	170	150			
	10	0	3	4	5	6	170	150	200	180		
	12	0	4	5	6	8	200	180	240	220		
	15	0	5	6	8	10	230	210	280	260		
	16	0	5	6	8	10	12	270	250	350	310	
	20	0	6	8	10	12	15	340	300	430	390	
	25	0	8	10	12	15	16	400	360	500	460	
	30	0	8	10	12	15	16	20	430	390	570	510
	35	0	20	25	30	40	480	440	630	570		
	40	0	20	25	30	40	580	520	750	680		
50	0	30	35	40	50	650	590	930	850			

\*SWSJJにTO.1はありません。

Order 注文例: 型式 - V - T  
SWSJJ8 - 3 - 0.5

Delivery 出荷日: 3 日目発送

Price 価格: ストック A 200円/1本 P.82

■数量スライド価格 (1円未満切り捨て) P.81

数量	1~49	50~69	70~99	100~199
値引率	基準単価	5%	10%	15%

表示数量超えはお見積り

■定型リングタイプ・パック販売 (1パック 10コ入り)

型式 Type	D	V 選択					T	¥基準単価				
		PACK-SWSJJ	PACK-SWSPT	PACK-SWSPP								
PACK-SWSJJ PACK-SWSPT PACK-SWSPP	8	0	3	4	5	6	1,280	1,020	1,530	1,280		
	10	0	3	4	5	6	1,530	1,280	1,790	1,530		
	12	0	4	5	6	8	1,790	1,530	2,130	1,870		
	15	0	5	6	8	10	2,040	1,790	2,470	2,210		
	16	0	5	6	8	10	12	2,380	2,130	3,150	2,640	
	20	0	6	8	10	12	15	3,060	2,550	3,830	3,320	
	25	0	8	10	12	15	16	3,570	3,060	4,510	3,910	
	30	0	8	10	12	15	16	20	3,830	3,320	5,100	4,340
	35	0	20	25	30	40	4,250	3,740	5,610	4,850		
	40	0	20	25	30	40	5,190	4,420	6,720	5,780		
50	0	30	35	40	50	5,780	5,020	8,330	7,230			

\*PACK-SWSJJにTO.1はありません。

Order 注文例: 型式 - V - T  
PACK-SWSJJ8 - 3 - 0.5

Delivery 出荷日: 3 日目発送

Price 価格: ストック A 200円/1本 P.82

■数量スライド価格 (1円未満切り捨て) P.81

数量	1~4	5~9	10~19	20~30
値引率	基準単価	5%	10%	15%

表示数量超えはお見積り

■シート定尺タイプ

型式 Type	T	¥基準単価											
		CIRAJ				CIRAT				CIRAP			
		TO.2	0.3	0.5	1.0	TO.1・0.2	0.3	0.5	1.0	TO.1・0.2	0.3	0.5	1.0
CIRAJ CIRAT CIRAP	20	330	400	270	270	260	320	290	310	180	220	180	180
	40	420	500	330	330	340	400	360	380	230	280	230	230
	60	540	650	450	450	430	520	460	480	310	370	310	310
	80	630	760	510	510	500	600	530	580	340	410	360	360
	100	870	1,040	660	690	670	810	720	770	470	560	470	470
	150	420	500	330	360	340	400	360	380	230	280	230	230
	200	510	610	420	420	410	490	430	480	290	340	290	290
	300	660	790	510	510	500	600	530	600	340	410	360	360
	400	960	1,150	720	750	720	860	770	890	490	590	490	520
	500	540	650	420	420	410	490	430	480	290	340	290	290
	600	690	830	510	540	530	630	550	620	360	440	360	360
	800	780	940	570	600	600	720	620	740	390	470	420	420
	1000	1,050	1,260	750	780	790	950	840	1,010	520	620	520	550
	1500	630	760	480	510	480	580	500	600	340	410	340	340
	2000	810	970	570	600	600	720	650	770	390	470	420	420
	3000	870	1,040	630	660	650	780	700	820	420	500	440	440
	4000	1,440	1,730	960	1,050	1,030	1,240	1,130	1,390	650	780	680	700
	6000	930	1,120	660	690	700	840	740	910	440	530	470	470
	8000	1,530	1,840	1,020	1,080	1,100	1,320	1,200	1,540	680	810	700	730
	10000	1,260	1,510	810	870	890	1,070	980	1,250	550	660	550	600
2													





SHIM RINGS SHIM RINGS PACKS  
**シムリングパック/シムリング**  
 -定型タイプ- -定型タイプ・フリー指定タイプ-



●類似寸法は加工部品Cナビガイドブック:P.384 ●CADデータフォルダ名: 35\_Washers

■定型・フリー指定タイプ **RoHS** ■定型パック販売 (30枚) **RoHS**

定型パック販売	定型タイプ	フリー指定タイプ	材質	厚さ(T)公差									
				0.01	0.02	0.03	0.05	0.1	0.2	0.3	0.5	0.8	1.0
PCIMRS	CIMRS	CIMRSF	SUS304	±0.003	±0.005	±0.003	±0.005	±0.01	±0.02	±0.03	±0.05	±0.04	±0.05
PCIMRB	CIMRB	CIMRBF	黄銅(C2801P)	-	-	-	±0.005	±0.02	±0.03	±0.04	±0.05	-	±0.08
PCIMR	CIMR	CIMRF	SPCC相当	-	-	-	-	±0.03	±0.04	±0.06	-	±0.11	

定型タイプ フリー指定タイプ

■定型パック販売 ①1パック30枚入り。 ②価格表記の無い極厚(T)は規格がありません。

型式	D 選択	T 選択	¥基準単価													
			PCIMRS		CIMRB		CIMR		PCIMR		T.05		T.1.0			
PCIMRS PCIMRB PCIMR	2	(0.01) PCIMRSのみ (0.05) CIMRS・ PCIMRBのみ	2,280	2,560	2,850	3,400	-	-	-	-	-	-	-	-	-	
	3		1,700	2,280	2,560	3,100	-	-	-	-	-	-	-	-	-	
	4		1,990	2,280	2,280	3,400	1,420	1,990	2,250	2,850	570	570	850	-	-	
	5		2,280	2,280	2,850	3,400	1,700	-	-	-	-	-	-	-	-	-
	6		2,280	2,280	2,850	3,400	-	-	-	-	-	-	-	-	-	-
	7		4,270	3,130	4,270	4,840	-	-	-	-	-	-	-	-	-	-
	8		6,550	3,130	4,270	4,840	-	-	-	-	-	-	-	-	-	-
	9		8,830	-	-	-	-	-	-	-	-	-	-	-	-	-
	10		9,430	4,560	5,130	6,270	-	-	-	-	-	-	-	-	-	-
	11		12,490	-	-	-	-	-	-	-	-	-	-	-	-	-
	12		15,810	4,690	5,670	6,750	-	-	-	-	-	-	-	-	-	-

Order 注文例 型式 - D - T  
 PCIMRS - 12 - 0.1

Delivery 出荷日 ③ 日目発送

在庫品 翌日出荷 ④ P.81

Price 価格 数量スライド価格 (①1円未満切り捨て) P.81

②ご希望によりPM5:00迄、当日出荷受付致します。

③ 日目発送

④ 価格表記の無い極厚(T)は規格がありません。

■定型タイプ

型式	D 選択	T 選択	¥基準単価													
			CIMRS		CIMRB		CIMR		T.05		T.1.0					
CIMRS CIMRB CIMR	2	(0.01) CIMRSのみ (0.02) (0.03) (0.05) CIMRS・ CIMRBのみ	130	140	150	-	-	-	-	-	-	-	-	-	-	
	3		80	90	100	120	60	80	90	110	60	60	70	-	-	
	4		130	140	150	-	-	-	-	-	-	-	-	-	-	-
	5		60	120	-	-	50	-	-	-	-	-	-	50	60	
	6		70	120	80	100	120	60	70	80	100	-	-	50	60	
	7		80	140	-	-	70	80	100	120	-	-	-	50	60	
	8		120	170	-	-	110	80	100	120	-	-	-	60	60	
	9		150	200	-	-	140	100	130	150	-	-	-	60	60	
	10		200	290	110	150	170	190	100	130	150	-	-	60	60	
	11		230	330	-	-	230	230	-	-	-	-	-	60	80	
	12		310	450	140	180	280	130	150	170	170	60	60	100	120	
	13		370	580	160	180	220	350	150	170	180	60	60	100	120	
	14		490	780	180	210	250	440	160	190	220	70	70	130	130	
	15		620	900	170	210	250	590	160	190	220	70	70	130	130	

Order 注文例 型式 - D - T  
 CIMRS - 12 - 0.1

Delivery 出荷日 ③ 日目発送

在庫品 翌日出荷 ④ P.81

Price 価格 数量スライド価格 (①1円未満切り捨て) P.81

②ご希望によりPM5:00迄、当日出荷受付致します。

③ 日目発送

④ 価格表記の無い極厚(T)は規格がありません。

■フリー指定タイプ

型式	D 指定 0.5mm単位	V 2.6以下選択 V3.0以上 0.5mm単位	T 選択	¥基準単価							
				CIMRSF・CIMRBF		CIMRF		T.05		T.1.0	
CIMRSF CIMRBF CIMRF	4.0~20	0 (穴無し) 2.0 2.6	(0.05) CIMRBF・ CIMRSFのみ (0.8) CIMRSFのみ	480	440	440	450	420	430	430	430
	20.5~40			480	450	460	470	440	440	450	460
	40.5~80			510	460	470	500	450	460	470	480
	80.5~100			570	470	480	570	460	460	480	490
	100.5~120			570	480	510	600	480	470	490	490
	120.5~140			590	530	590	650	480	470	500	500
	140.5~160			620	540	590	690	490	480	520	520
	160.5~180			870	760	880	1,090	560	540	660	660
	180.5~200			800	600	730	950	550	530	700	700
	200.5~214			820	650	790	1,140	580	580	690	690
214.5~230	1,090	850	1,030	1,280	680	680	860	860			
230.5~250	1,220	1,090	1,240	1,790	780	930	1,060	1,060			
	1,250	1,090	1,240	1,860	780	1,000	1,140	1,140			

Alteration 追加加工 型式 - D - V - T - (KC)  
 CIMRSF - D22 - V18 - T.01 - KC

③ 日目発送

④ フリー指定タイプのみ適用

Alteration Code Spec. ¥/Code

キー溝逃し加工

キー溝逃し加工をします。  
 [指定方法] KC  
 加工条件 ① 8 ≤ V ≤ 49.5

V b t D-V  
 8 ~ 10.5 3 2.0 7以上  
 11 ~ 12.5 4 2.5 8以上  
 13 ~ 17.5 5 3.0 10以上  
 18 ~ 22.5 6 3.5 12以上  
 23 ~ 30.5 8 4.0 14以上  
 31 ~ 38.5 10 4.0 14以上  
 39 ~ 42.5 12 4.0 14以上  
 43 ~ 49.5 14 4.5 16以上

Order 注文例 型式 - D - V - T  
 CIMRF - D73 - V43 - T1.0

Delivery 出荷日 ③ 日目発送

在庫品 翌日出荷 ④ P.81

Price 価格 数量スライド価格 (①1円未満切り捨て) P.81

②ご希望によりPM5:00迄、当日出荷受付致します。

③ 日目発送

④ 価格表記の無い極厚(T)は規格がありません。



PRECISION SHIM RINGS WAVE WASHERS  
**精密級シムリング/ウェーブワッシャ**  
 -定型タイプ・フリー指定タイプ-



●CADデータフォルダ名: 35\_Washers

■精密級シムリング **RoHS**

定型パック販売	フリー指定タイプ	材質
PCIMAS	CIMASF	SUS304
-	CIMAKF	SK5 45HRC~

■定型パック販売 ①1パック10枚入り。

型式	D	V (内径) 選択	T 選択	¥基準単価		
				T.05	T.0.1~0.3	T.0.5~1.0
PCIMAS	5	3	0.05 0.1 0.2 0.3 0.5 1.0	3,120	2,340	2,280
	6	3 4		-	-	-
	7	3 4 5		-	-	-
	8	4 5 6		-	-	-
	9	4 5 6		-	-	-
	10	4 5 6 7 8		-	-	-
	11	5 6 7 8		-	-	-
	12	5 6 7 8		-	-	-
	13	7 8		-	-	-
	14	7 8 10		-	-	-
	15	8 10 12		-	-	-
	16	8 10 12		-	-	-
	20	8 10 12		-	-	-
	22	8 10 12		-	-	-
	25	8 10 12 18 21		-	-	-
28	21 23	-	-	-		
30	24	-	-	-		

■フリー指定タイプ

型式	D	V	T 選択	¥基準単価	
				T.05~0.3	T.0.4~1.0
CIMASF (SUS304) CIMAKF (SK5)	5 ~ 10	0 (穴無し) 3.0~48.0	0.05 0.06 0.07 0.08 0.09 0.1 0.15 0.2 0.25 0.3 0.4 0.5 0.6 0.7 0.8 0.9 1.0	780	760
	10.5~20		960	900	
	20.5~30		1,260	1,210	
	30.5~40		1,570	1,400	
	40.5~50		1,860	1,680	

T ≤ 0.2...V ≤ D - 2 0.3 ≤ T...V ≤ D - 4

Order 注文例 型式 - D - V - T  
 PCIMAS - D25 - V10 - T0.2  
 CIMASF - D25 - V10 - T0.2

Delivery 出荷日 ③ 日目発送

在庫品 翌日出荷 ④ P.82

Price 価格 数量スライド価格 (①1円未満切り捨て) P.81

②ご希望によりPM5:00迄、当日出荷受付致します。

③ 日目発送

④ 価格表記の無い極厚(T)は規格がありません。

■ウェーブワッシャ **RoHS**

Order 注文例 型式 - V - D  
 PACK - WWWS - V3 - D4.2

Delivery 出荷日 ③ 日目発送

在庫品 翌日出荷 ④ P.81

Price 価格 数量スライド価格 (①1円未満切り捨て) P.81

②ご希望によりPM5:00迄、当日出荷受付致します。

Order 注文例 型式 - V - D  
 PACK - WWWS - V3 - D4.2

Delivery 出荷日 ③ 日目発送

在庫品 翌日出荷 ④ P.81

Price 価格 数量スライド価格 (①1円未満切り捨て) P.81

②ご希望によりPM5:00迄、当日出荷受付致します。

35  
カラー・シム  
ワッシャ



SQUARE SHIMS FOR MOTOR BASE・PILLOW BLOCK

# 角シム

—モータベース用・ピロブロック用—

類似寸法は加工部品Cナビガイドブック：P.384  
CADデータフォルダ名：35\_Washers



Type		M材質	
モータベース用	ピロブロック用	CIMM	CIMSN
		CIMMB	CIMSB
		CIMMS	CIMSS
PACK-CIMMS PACK-CIMSS		SUS304	

T	SPCC相当	黄銅	SUS304
0.05	—	±0.005	±0.005
0.1	±0.03	±0.02	±0.02
0.2	±0.03	±0.03	±0.03
0.5	±0.06	±0.05	±0.04
1.0	±0.11	±0.08	±0.05

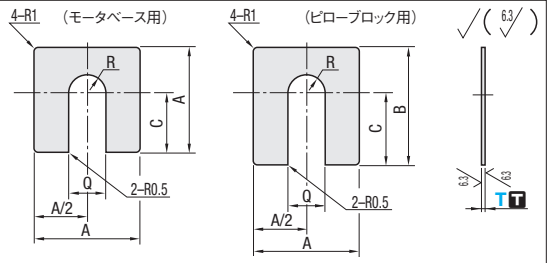

## モータベース用

Type	No.	T 選択	A	C	Q	¥基準単価														
						CIMM					CIMMB					CIMMS				
						T0.1	T0.2	T0.5	T1.0	T0.05	T0.1	T0.2	T0.5	T1.0	T0.05	T0.1	T0.2	T0.5	T1.0	
CIMM CIMMB CIMMS	2009	(0.05)	20	10	9	120	120	130	140	190	120	130	170	220	180	130	140	200	260	
	3013		30	15	13	120	130	140	220	200	130	140	200	280	190	140	160	230	310	
	4312		43	22	12	140	160	200	260	230	150	160	220	340	220	170	180	270	390	
	4814		48	24	14	150	160	200	270	240	150	160	260	390	230	180	190	280	440	
	5314		53	27	14	150	160	200	270	260	160	170	270	440	250	190	200	310	480	
	6816		68	34	16	160	180	230	280	310	190	210	370	610	300	220	240	390	650	
	8320		83	42	20	170	200	230	290	390	220	260	490	840	370	300	310	500	850	
	9825		98	49	25	200	220	260	330	470	270	310	620	1,120	440	350	370	630	1,150	
	11830		118	54	30	230	260	310	460	840	310	390	820	1,520	800	440	460	840	1,600	
	20036		200	100	36	360	430	510	770	1,690	650	810	2,030	3,800	1,780	1,010	1,030	2,050	3,980	

Order 注文例 型式 — T  
CIMM2009 — 0.5

Delivery 出荷日 3 日目発送  
在庫あり 翌日出荷 P81  
ご希望によりPM5:00迄、当日出荷受付致します。

Price 価格

数量スライド価格 (1円未満切り捨て) P81  
数量 1~99 100~199 200~249 250~499  
値引率 基準単価 5% 10% 15%

## ピロブロック用

Type	No.	T 選択	A	B	C	Q	対応ピロブロック	¥基準単価																									
								CIMSN					CIMSB					CIMSS															
								T0.1	T0.2	T0.5	T1.0	T0.05	T0.1	T0.2	T0.5	T1.0	T0.05	T0.1	T0.2	T0.5	T1.0												
CIMSN CIMSB CIMSS	204A	(0.05)	40	27	15	13	UCPA204 UCUP204	50	60	190	50	70	200	70	90	160																	
	205A		45	30	16	13	UCPA205 UCUP205																										
	206A		50	36	22	17	UCPA206 UCUP206																										
	207A		55	41	26	17	UCPA207 UCUP207																										
	208A		58	41	25	17	UCPA208 UCUP208																										
	204		38	42	26	13	UCP-204														60	80	250	60	80	270	80	110					
	205		38	42	25	13	UCP-205																										
	206		48	54	32	17	UCP-206																										
	207		48	54	34	17	UCP-207																										
	208		54	58	35	17	UCP-208																										
209	54	60	38	17	UCP-209																												
210	60	65	42	20	UCP-210																												

Order 注文例 型式 — T  
CIMSS204A — 0.1

Delivery 出荷日 3 日目発送  
在庫あり 翌日出荷 P81  
ご希望によりPM5:00迄、当日出荷受付致します。

Price 価格

数量スライド価格 (1円未満切り捨て) P81  
数量 1~99 100~199 200~249 250~499  
値引率 基準単価 5% 10% 15%

## モータベース用・ピロブロック用 バック販売

Type	No.	T 選択	A	B	C	Q	¥基準単価				
							T0.05	T0.1	T0.2	T0.5	T1.0
モータベース用 (SUS304) PACK-CIMMS	2009	0.05	20	—	10	9	1,620	1,170	1,260	1,800	2,340
	3013		30	—	15	13	1,710	1,260	1,440	2,070	2,790
	4312		43	—	22	12	1,980	1,530	1,620	2,430	3,510
	4814		48	—	24	14	2,070	1,620	1,710	2,520	3,960
	5314		53	—	27	14	2,250	1,710	1,800	2,790	4,320
	6816		68	—	34	16	2,700	1,980	2,160	3,510	5,850
	8320		83	—	42	20	3,330	2,700	2,790	4,500	7,650
	9825		98	—	49	25	3,740	2,970	3,140	5,350	9,770
	204A		40	27	15	13	1,900	660	760	850	1,520
	205A		45	30	16	13	1,900	660	760	850	1,520
206A	50	36	22	17	1,900	660	760	850	1,520		
207A	55	41	26	17	1,900	660	760	850	1,520		
208A	58	41	25	17	1,900	660	760	850	1,520		
204	38	42	26	13	1,900	660	760	850	1,520		
205	38	42	25	13	1,900	660	760	850	1,520		
206	48	54	32	17	2,560	760	760	1,040	1,520		
207	48	54	34	17	2,560	760	760	1,040	1,520		
208	54	58	35	17	2,560	760	760	1,040	2,180		
209	54	60	38	17	2,560	760	760	1,140	2,180		
210	60	65	42	20	2,560	760	760	1,140	2,180		

Order 注文例 型式 — T  
PACK-CIMMS2009 — 0.5  
PACK-CIMSS204A — 0.1

Delivery 出荷日 在庫あり 翌日出荷 P81  
ご希望によりPM5:00迄、当日出荷受付致します。

Price 価格

数量スライド価格 (1円未満切り捨て) P81  
数量 1~9 10~19 20~49 50~99  
値引率 基準単価 5% 10% 15%

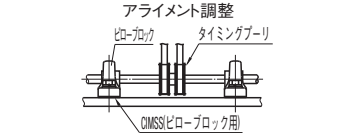
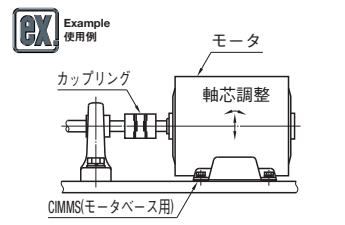

SQUARE SHIMS FOR ADJUSTMENT / SHIM -SPLIT TYPE-

# 角シム/シム (割りタイプ)

—調整用—

類似寸法は加工部品Cナビガイドブック：P.384  
CADデータフォルダ名：35\_Washers

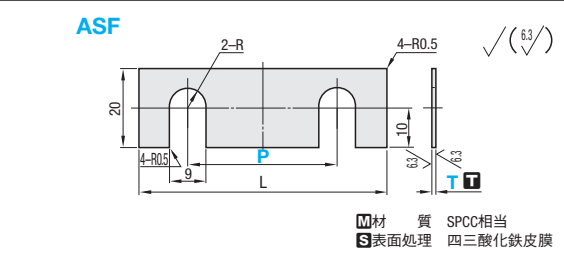
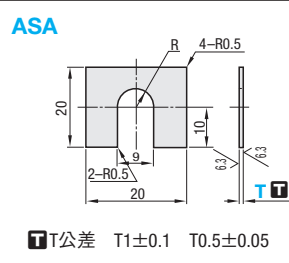

Type	T	¥基準単価	¥スライド単価
		1~49コ	50~
ASA	0.5	90	80
	1.0	130	110

Type	T	P	L	¥基準単価	¥スライド単価
				1~49コ	50~
ASF	0.5	30	50	100	90
		40	60	100	90
		50	70	120	100
	1.0	30	50	150	130
		40	60	150	130
		50	70	170	150

Order 注文例 型式 — P  
ASA0.5  
ASF0.5 — 30

Delivery 出荷日 在庫あり 翌日出荷 P81  
ご希望によりPM5:00迄、当日出荷受付致します。

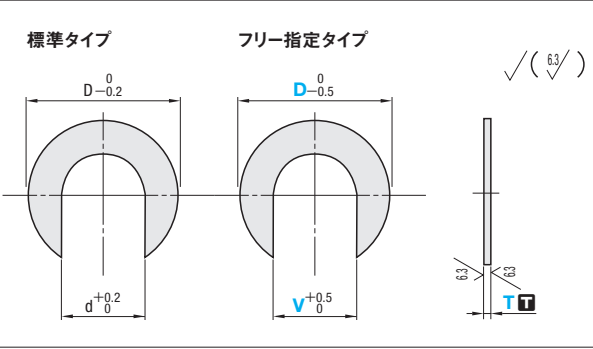

Type	No.	T	d	D	¥基準単価		
					CIMW	CIMWB	CIMWS
CIMW CIMWB CIMWS	6	(0.05)	6.5	12	100	100	
	8		8.5	15			
	10		10.5	20			
	12		12	25			
	16		17	30			
	20		21	35			
	24		25	40			
	30		31	50			

Type	No.	T 選択	d	D	¥基準単価			
					T0.05	T0.1~0.3	T0.5	T1.0
PACK-CIMWS	6	0.05	6.5	12	960	900	950	970
	8		8.5	15	960	900	950	970
	10		10.5	20	1,050	990	1,040	1,060
	12		13	25	1,050	990	1,040	1,060
	16		17	30	1,240	1,170	1,230	1,260
	20		21	35	1,240	1,170	1,230	1,260
	24		25	40	1,530	1,440	1,520	1,550
	30		31	50	1,530	1,440	1,520	1,550

Order 注文例 型式 — T  
CIMW10 — 0.2

Delivery 出荷日 3 日目発送  
在庫あり 翌日出荷 P81  
ご希望によりPM5:00迄、当日出荷受付致します。

Price 価格

数量スライド価格 (1円未満切り捨て) P81  
数量 1~9 10~19 20~49 50~99  
値引率 基準単価 5% 10% 15%

Order 注文例 型式 — T  
PACK-CIMWS12 — 0.1

Delivery 出荷日 在庫あり 翌日出荷 P81  
ご希望によりPM5:00迄、当日出荷受付致します。

Price 価格

数量スライド価格 (1円未満切り捨て) P81  
数量 1~9 10~19 20~49 50~99  
値引率 基準単価 5% 10% 15%

Type	T 選択	V 選択	D 指定mm単位	¥基準単価												
				CIMWF			CIMWBF			CIMWSF						
				T0.1~0.3	T0.5	T1.0	T0.05	T0.1~0.3	T0.5	T1.0	T0.05	T0.1~0.3	T0.5	T1.0		
CIMWF CIMWBF CIMWSF	(0.05)	CIMWBF・CIMWSFのみ	10~20	960	960	970	1,280	1,150	1,160	1,160	1,290	1,160	1,160	1,170		
				6.5												
				8.5												
				10.5												
				13												
				17												
21~50	0.1	0.2	0.3	0.5	1.0	1,040	1,040	1,070	1,390	1,240	1,270	1,270	1,400	1,260	1,260	1,290
						0.1										
						0.2										
						0.3										
						0.5										
						1.0										

Order 注文例 型式 — T - V - D  
CIMWF — 0.2 - 8.5 - 20

Delivery 出荷日 3 日目発送  
在庫あり 翌日出荷 P81  
ご希望によりPM5:00迄、当日出荷受付致します。

Price 価格

数量スライド価格 (1円未満切り捨て) P81  
数量 1~9 10~19 20~49 50~99  
値引率 基準単価 5% 10% 15%





SQUARE SHIMS

# 角シム

—キリ欠き穴タイプ・丸穴タイプ—

◎類似寸法は加工部品Cナビガイドブック：P.384・386



## ■キリ欠き穴タイプ ■丸穴タイプ RoHS



型式	材質	厚さ(T)公差										
		0.05	0.1	0.2	0.3	0.5	1.0	2.0	3.0			
SPCC相当	—	±0.03	±0.04	±0.06	±0.11	±0.17	—	キリ欠き穴タイプ加工条件 ◎f≥3 ◎a≥3 ◎m≥3 ◎n≥3				
ASAFA	ASFFB	ASCFB	黄銅(C2801P)	±0.005	±0.02	±0.03	±0.04	±0.05	±0.08	±0.12	±0.15	
ASAFA	ASFFB	ASCFB	SUS304	±0.005	±0.02	±0.03	±0.035	±0.04	±0.05	±0.20	±0.25	

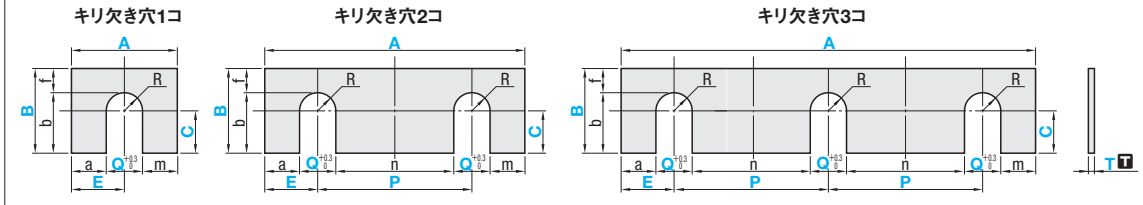

型式 Type	A 指定1mm単位	B 指定1mm単位	T (選択)	Q 選択	指定0.1mm単位			
					E	C	P	
SPCC相当 黄銅 SUS304	10~150	10~150	(0.05) 0.1 0.2 0.3 0.5 1.0 2.0 (3.0)	5.8 6.5 7.5 8.5 10.5 12 13 14	15 16 17 20 21 25 30 31	Q/2+3~	0 B-(Q/2+3)	◎穴1コタイプ は指定不要
穴1コ ASAFA ASFFB ASCFB	10~150	10~150						
穴2コ ASFFB ASFFB ASFFB	16~200	10~200						◎穴3コタイプ は指定不要
穴3コ ASCFB ASCFB ASCFB								

◎T(0.05), (3.0)はSPCC相当材で指定できません。

Order 注文例

型式 - A - B - T - Q - E - C - P

ASFFB - A100 - B25 - T1.0 - Q12 - E15 - C12 - P70

型式	材質	厚さ(T)公差									
		0.05	0.1	0.2	0.3	0.5	1.0	2.0	3.0		
SPCC相当	—	±0.03	±0.04	±0.06	±0.11	±0.17	—	丸穴タイプ加工条件 ◎f≥2 ◎a≥2 ◎m≥2 ◎n≥2 ◎h≥2			
ASACB	ASFCB	ASCCB	黄銅(C2801P)	±0.005	±0.02	±0.03	±0.04	±0.05	±0.08	±0.12	±0.15
ASACB	ASFCB	ASCCB	SUS304	±0.005	±0.02	±0.03	±0.035	±0.04	±0.05	±0.20	±0.25

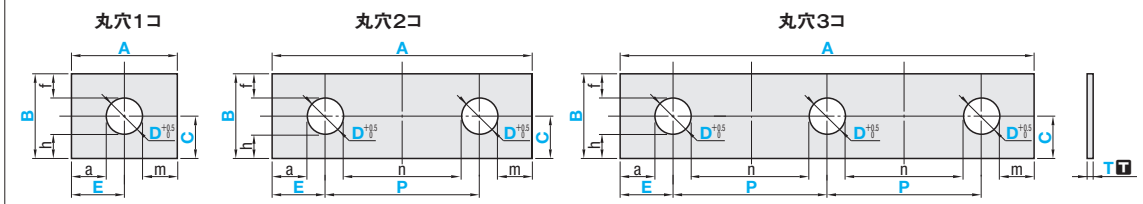

型式 Type	A 指定1mm単位	B 指定1mm単位	T (選択)	D 指定1mm単位	指定0.1mm単位		
					E	C	P
SPCC相当 黄銅 SUS304	10~150	10~150	(0.05) 0.1 0.2 0.3 0.5 1.0 2.0 (3.0)	3~100	D/2+3~	0 B-(D/2+2)	◎穴1コタイプ は指定不要
穴1コ ASACB ASFCB ASFCB	10~150	10~150					
穴2コ ASFCB ASFCB ASFCB	15~200	10~200					◎穴3コタイプ は指定不要
穴3コ ASCCB ASCCB ASCCB							

◎T(0.05), (3.0)はSPCC相当材で指定できません。

Order 注文例

型式 - A - B - T - D - E - C - P

ASACB - A50 - B25 - T0.1 - D7.5 - E25 - C11

ASCCB - A120 - B15 - T3.0 - D10 - E15 - C7 - P45

Delivery 出荷日 **3** 日目発送

在庫 T 200円/1本 無料

価格 P.82

数量スライド価格 (◎1円未満切り捨て) P.81

数量	1~4	5~9	10~19	20~49	50~100	101以上
値引率	—	10%	20%	30%	35%	出荷日・価格 共に見積
出荷日	—	通常	通常	通常	+3日	—

◎101以上お見積りになります。

### ■キリ欠き穴・丸穴 1コタイプ

A	B	¥基準単価											
		ASAFA・ASACB			ASAFA・ASACB			ASAFA・ASACB			ASAFA・ASACB		
		T0.1~0.5	T1.0	T2.0	T0.05	T0.1~0.5	T1.0	T2.0~3.0	T0.05	T0.1~0.5	T1.0	T2.0~3.0	
10~50	10~50	550	550	750	650	650	800	890	570	570	730	810	
	51~100	760	780	790	1,040	860	870	1,020	900	740	780	880	
	101~150	770	790	800	1,220	880	900	1,160	1,050	780	790	1,010	

### ■キリ欠き穴・丸穴 2コタイプ

A	B	¥基準単価											
		ASFFB・ASFCB			ASFFB・ASFCB			ASFFB・ASFCB			ASFFB・ASFCB		
		T0.5	T1.0	T2.0	T0.05	T0.1~0.5	T1.0	T2.0~3.0	T0.05	T0.1~0.5	T1.0	T2.0~3.0	
15~50	10~50	650	850	900	700	800	900	1,170	750	750	880	1,030	
	51~100	950	960	960	1,290	1,010	1,030	1,310	1,160	860	930	1,150	
	101~150	960	970	980	1,490	1,020	1,040	1,470	1,300	890	960	1,290	

### ■キリ欠き穴・丸穴 3コタイプ

A	B	¥基準単価											
		ASCFB・ASCCB			ASCFB・ASCCB			ASCFB・ASCCB			ASCFB・ASCCB		
		T0.5	T1.0	T2.0	T0.05	T0.1~0.5	T1.0	T2.0~3.0	T0.05	T0.1~0.5	T1.0	T2.0~3.0	
15~50	10~50	890	920	920	1,040	990	1,010	1,180	950	850	880	1,060	
	51~100	960	970	970	1,310	1,020	1,040	1,320	1,190	880	950	1,180	
	101~150	970	980	990	1,510	1,030	1,050	1,490	1,340	910	980	1,320	



SHIM PLATES  
**シムプレート**  
一定尺タイプ・フリー指定タイプ

**納期短縮**  
**プライスダウン**  
最大50%  
:値下げ価格



価格改定  
FGSMの価格改定は2009年6月1日  
より実施いたします。ご迷惑をおかけ  
いたしますが、5月末日迄は旧カタ  
ログの価格表をご参照ください。

類似寸法は加工部品Cナビガイドブック：P.384

CADデータフォルダ名：35\_Washers

■シムプレート **RoHS**

Type	フリー指定タイプ	材質	厚さ(T)公差					
定尺タイプ			0.05	0.1	0.2	0.3	0.5	1.0
CIRA	CIRAF	SPCC相当	—	±0.03	±0.04	±0.06	±0.11	
CIRAB	CIRABF	黄銅(C2801P)	±0.005	±0.02	±0.03	±0.04	±0.05	±0.08
CIRAS	CIRASF	SUS304	±0.005	±0.02	±0.03	±0.035	±0.04	±0.05

材質: SPCC相当, 黄銅(C2801P), SUS304

公差: ±0.03, ±0.04, ±0.06, ±0.11, ±0.005, ±0.02, ±0.03, ±0.04, ±0.05, ±0.08, ±0.005, ±0.02, ±0.03, ±0.035, ±0.04, ±0.05

寸法図: A, B, T, 6.3

■定尺タイプ

型式	Type	T	選択		¥基準単価																							
			A	B	CIRA			CIRAB			CIRAS			CIRAS			CIRAS											
CIRA CIRAB CIRAS	(0.05) CIRAは ありません	0.1 0.2 0.3 0.5 1.0	20	30	40	0.1	0.2	0.3	0.5	1.0	0.05	0.1	0.2	0.3	0.5	1.0	0.05	0.1	0.2	0.3	0.5	1.0						
			30	40	50	340	350	360	380	400	510	330	340	350	420	570	420	380	390	390	530	720	420	380	390	390	530	720
			40	50	60	420	440	450	480	500	590	410	430	440	530	710	520	470	490	490	660	900	520	470	490	490	660	900
			50	60	70	480	500	510	540	570	630	460	480	500	600	810	590	540	550	550	750	1,020	590	540	550	550	750	1,020
			60	70	80	530	550	570	600	640	800	510	540	550	670	900	660	600	620	620	840	1,140	660	600	620	620	840	1,140
			70	80	90	420	440	450	480	500	590	410	430	440	530	710	520	470	490	490	660	900	520	470	490	490	660	900
			80	90	100	480	500	510	540	570	630	460	480	500	600	810	590	540	550	550	750	1,020	590	540	550	550	750	1,020
			90	100	120	610	640	660	700	740	760	590	620	640	770	1,040	760	690	710	710	970	1,320	760	690	710	710	970	1,320
			100	120	150	420	440	450	480	500	630	410	430	440	530	710	520	470	490	490	660	900	520	470	490	490	660	900
			120	150	200	610	640	660	700	740	720	590	620	640	770	1,040	760	690	710	710	970	1,320	760	690	710	710	970	1,320
			150	200	250	500	530	540	570	600	760	490	510	530	630	850	620	570	580	580	800	1,080	620	570	580	580	800	1,080
			200	250	300	890	930	960	1,010	1,070	1,050	860	900	930	1,120	1,520	1,100	1,000	1,030	1,030	1,410	1,920	1,100	1,000	1,030	1,030	1,410	1,920
250	300	350	700	730	750	790	830	720	680	710	730	880	1,190	860	780	810	810	1,100	1,500	860	780	810	810	1,100	1,500			
300	350	400	500	530	540	570	600	760	490	510	530	630	850	620	570	580	580	800	1,080	620	570	580	580	800	1,080			
350	400	450	890	930	960	1,010	1,070	1,050	860	900	930	1,120	1,520	1,100	1,000	1,030	1,030	1,410	1,920	1,100	1,000	1,030	1,030	1,410	1,920			
400	450	500	700	730	750	790	830	720	680	710	730	880	1,190	860	780	810	810	1,100	1,500	860	780	810	810	1,100	1,500			
450	500	550	500	530	540	570	600	760	490	510	530	630	850	620	570	580	580	800	1,080	620	570	580	580	800	1,080			
500	550	600	890	930	960	1,010	1,070	1,050	860	900	930	1,120	1,520	1,100	1,000	1,030	1,030	1,410	1,920	1,100	1,000	1,030	1,030	1,410	1,920			
550	600	650	700	730	750	790	830	720	680	710	730	880	1,190	860	780	810	810	1,100	1,500	860	780	810	810	1,100	1,500			
600	650	700	500	530	540	570	600	760	490	510	530	630	850	620	570	580	580	800	1,080	620	570	580	580	800	1,080			
650	700	750	890	930	960	1,010	1,070	1,050	860	900	930	1,120	1,520	1,100	1,000	1,030	1,030	1,410	1,920	1,100	1,000	1,030	1,030	1,410	1,920			
700	750	800	700	730	750	790	830	720	680	710	730	880	1,190	860	780	810	810	1,100	1,500	860	780	810	810	1,100	1,500			
750	800	850	500	530	540	570	600	760	490	510	530	630	850	620	570	580	580	800	1,080	620	570	580	580	800	1,080			
800	850	900	890	930	960	1,010	1,070	1,050	860	900	930	1,120	1,520	1,100	1,000	1,030	1,030	1,410	1,920	1,100	1,000	1,030	1,030	1,410	1,920			
850	900	950	700	730	750	790	830	720	680	710	730	880	1,190	860	780	810	810	1,100	1,500	860	780	810	810	1,100	1,500			
900	950	1,000	500	530	540	570	600	760	490	510	530	630	850	620	570	580	580	800	1,080	620	570	580	580	800	1,080			
950	1,000	1,050	890	930	960	1,010	1,070	1,050	860	900	930	1,120	1,520	1,100	1,000	1,030	1,030	1,410	1,920	1,100	1,000	1,030	1,030	1,410	1,920			
1,000	1,050	1,100	700	730	750	790	830	720	680	710	730	880	1,190	860	780	810	810	1,100	1,500	860	780	810	810	1,100	1,500			
1,050	1,100	1,150	500	530	540	570	600	760	490	510	530	630	850	620	570	580	580	800	1,080	620	570	580	580	800	1,080			
1,100	1,150	1,200	890	930	960	1,010	1,070	1,050	860	900	930	1,120	1,520	1,100	1,000	1,030	1,030	1,410	1,920	1,100	1,000	1,030	1,030	1,410	1,920			
1,150	1,200	1,250	700	730	750	790	830	720	680	710	730	880	1,190	860	780	810	810	1,100	1,500	860	780	810	810	1,100	1,500			
1,200	1,250	1,300	500	530	540	570	600	760	490	510	530	630	850	620	570	580	580	800	1,080	620	570	580	580	800	1,080			
1,250	1,300	1,350	890	930	960	1,010	1,070	1,050	860	900	930	1,120	1,520	1,100	1,000	1,030	1,030	1,410	1,920	1,100	1,000	1,030	1,030	1,410	1,920			
1,300	1,350	1,400	700	730	750	790	830	720	680	710	730	880	1,190	860	780	810	810	1,100	1,500	860	780	810	810	1,100	1,500			
1,350	1,400	1,450	500	530	540	570	600	760	490	510	530	630	850	620	570	580	580	800	1,080	620	570	580	580	800	1,080			
1,400	1,450	1,500	890	930	960	1,010	1,070	1,050	860	900	930	1,120	1,520	1,100	1,000	1,030	1,030	1,410	1,920	1,100	1,000	1,030	1,030	1,410	1,920			
1,450	1,500	1,550	700	730	750	790	830	720	680	710	730	880	1,190	860	780	810	810	1,100	1,500	860	780	810	810	1,100	1,500			
1,500	1,550	1,600	500	530	540	570	600	760	490	510	530	630	850	620	570	580	580	800	1,080	620	570	580	580	800	1,080			
1,550	1,600	1,650	890	930	960	1,010	1,070	1,050	860	900	930	1,120	1,520	1,100	1,000	1,030	1,030	1,410	1,920	1,100	1,000	1,030	1,030	1,410	1,920			
1,600	1,650	1,700	700	730	750	790	830	720	680	710	730	880	1,190	860	780	810	810	1,100	1,500	860	780	810	810	1,100	1,500			
1,650	1,700	1,750	500	530	540	570	600	760	490	510	530	630	850	620	570	580	580	800	1,080	620	570	580	580	800	1,080			
1,700	1,750	1,800	890	930	960	1,010	1,070	1,050	860	900	930	1,120	1,520	1,100	1,000	1,030	1,030	1,410	1,920	1,100	1,000	1,030	1,030	1,410	1,920			
1,750	1,800	1,850	700	730	750	790	830	720	680	710	730	880	1,190	860	780	810	810	1,100	1,500	860	780	810	810	1,100	1,500			
1,800	1,850	1,900	500	530	540	570	600	760	490	510	5																	