

# BALL BEARING GUIDE POST SETS - PRESS FIT POST -

## ダイセット用ボールガイドポストセット

- 圧入ポスト -



※セットの場合は、規格寸法のみとなります。  
規格寸法以外は、各部品単品に追加加工 (P.961 ~ 963) を  
ご指示の上、ご注文ください。

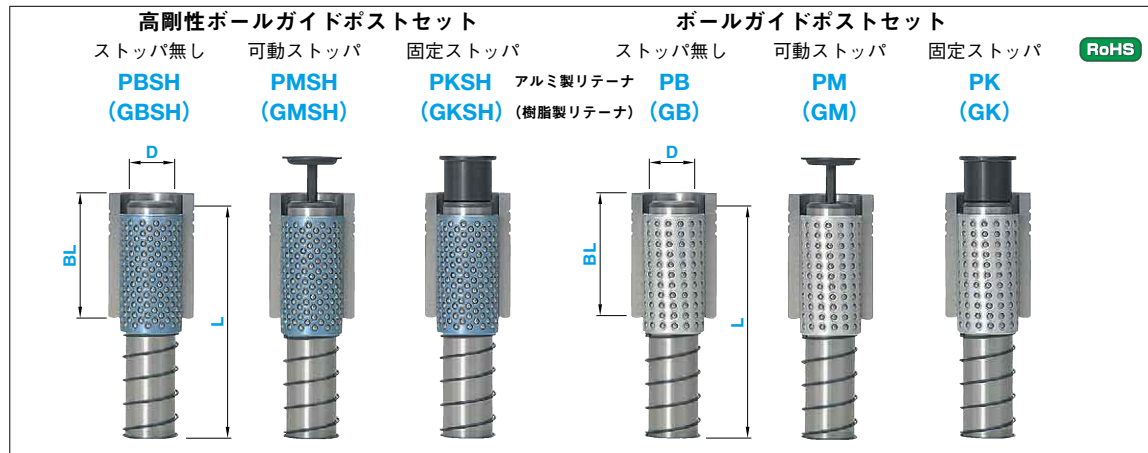

RoHS

型式	構成部品					
	①	②	③	④	⑤	⑥
PBSH	MSP		MBSH	SWP		
PMSH	BSPM		MBSH	STM		
PKSH	BSPK	MBB	SWP	STM	STK	
GBSH	MSP	LBB				
GMSH	BSPM		MBJH	STM		
GKSH	BSPK				STK	
PB	MSP		MBS			
PM	BSPM		MBS	STM		
PK	BSPK	MBB	SWP		STK	
GB	MSP	LBB				
GM	BSPM		MBJ	STM		
GK	BSPK				STK	

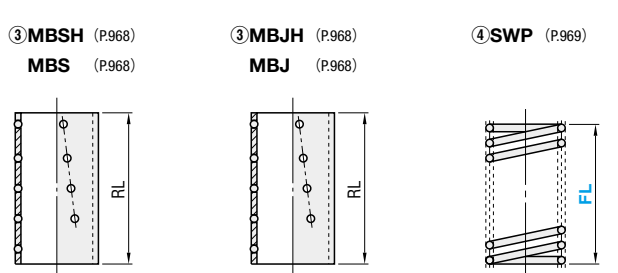
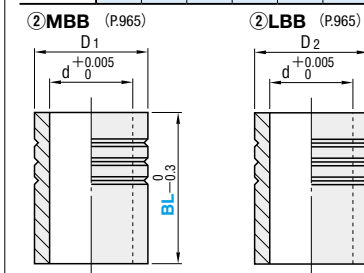
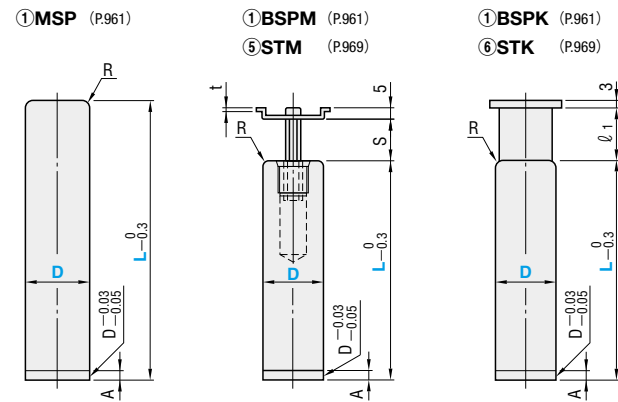

MSP・BSPM・BSPK			
D	A	R	t
20	+0.020	2.0	1.6
22	+0.015	3.0	
25		3.0	
28	+0.025	5	2.0
32	+0.020	3.5	
38	+0.030	6	
45	+0.025		
50	+0.035	7	5.0
60	+0.030		

MBB・LBB			
d	D1・D2	D1	D2
26	37	+0.5	+0.3
28	40		
31	45		
36	50	0	-0.007
40	55		
48	64		
55	74	0	-0.008
60	83		
70	95		
		0	-0.010

RL	S	l1
50	0 ~ 19	15
60	0 ~ 23	20
75	0 ~ 30	25
90	0 ~ 37	30
110	0 ~ 47	35

■プッシュ取付方法 (接着剤 P.974)

MBB	デブコン接着	-
LBB	ロックタイト接着	ロックタイト No.638 (LOC638)

■高剛性ボールガイドポストセットとは  
ボールリテーナのボール数を約1.6倍にした高剛性ボールリテーナ (MBSH・MBJH) を使用し、低コストでプレーンガイドに迫る剛性を実現しました。

型式	D	L										②MBB・LBB		RL	FL 指定10mm単位
		Type	BL												
PBSH	20	100	110	120	130	140	150	160	170	180	M (MBB)	50	50	40 ~ 140	
PMSH	22	120	130	140	150	160	170	180	50	50		40 ~ 140			
PKSH	25	120	130	140	150	160	170	180	60	60		40 ~ 150			
GBSH	28	140	150	160	170	180	190	200	60	60		50 ~ 150			
GMSH	32	160	170	180	190	200	220	240	80	75		50 ~ 150			
GKSH	32	160	170	180	190	200	220	240	100	90		70 ~ 190			
PB	38	180	190	200	220	240	260	80	75	80 ~ 190					
PM	45	180	190	200	220	240	260	100	90	80 ~ 190					
PK	50	200	220	240	260	100	90	80 ~ 190							
GB	50	200	220	240	260	120	110	80 ~ 190							
GM	60	200	220	240	260	100	90	80 ~ 190							
GK	60	200	220	240	260	120	110	80 ~ 190							

Order 注文例: 型式 GBSH - L 25 - ② L60 - ④ FL 120

Delivery 出荷日: 在庫品 翌日出荷 P.39

発注記号: GBSH 25 15 L6 - 12

■数量スライド価格 (1円未満切り捨て) P.39

数量区分	標準対応	個別対応大口
数量	1 ~ 9	10 ~ 19
値引率	5%	10%
	標準単価	15%

◎表示数量超えはWOSにてご確認ください。

D	L	¥標準単価 1 ~ 9セット															
		高剛性ボールガイドポストセット								ボールガイドポストセット							
		PBSH		PMSH・PKSH		GBSH		GMSH・GKSH		PB		PM・PK		GB		GM・GK	
		M	L	M	L	M	L	M	L	M	L	M	L	M	L		
20	100~140	3,220	3,760	3,830	4,370	3,010	3,540	3,620	4,160	2,660	3,200	3,280	3,820	2,490	3,030	3,100	3,640
	150~180	3,310	3,850	3,930	4,470	3,090	3,640	3,710	4,250	2,750	3,280	3,370	3,900	2,580	3,120	3,200	3,740
22	120~150	3,740	4,320	4,400	4,980	3,490	4,070	4,160	4,730	3,130	3,710	3,790	4,370	2,920	3,490	3,580	4,170
	160~180	3,820	4,400	4,480	5,060	3,570	4,160	4,240	4,810	3,200	3,790	3,870	4,450	3,000	3,580	3,660	4,240
25	120~150	4,480	5,150	5,190	5,860	4,220	4,880	4,920	5,580	3,670	4,330	4,380	5,030	3,500	4,170	4,210	4,870
	160~180	4,530	5,190	5,270	5,930	4,260	4,920	5,010	5,660	3,710	4,380	4,460	5,120	3,550	4,210	4,290	4,950
28	140~170	5,150	5,810	5,930	6,600	4,800	5,470	5,580	6,250	4,390	5,050	5,170	5,840	4,060	4,720	4,850	5,510
	180~200	5,270	5,910	6,090	6,760	4,930	5,560	5,750	6,410	4,510	5,170	5,340	6,000	4,180	4,820	5,020	5,670
32	160~190	6,620	7,370	7,530	8,270	6,200	6,940	7,110	7,850	5,580	6,340	6,500	7,250	5,260	6,010	6,170	6,920
	200~240	6,830	7,570	7,690	8,440	6,400	7,160	7,280	8,020	5,810	6,550	6,670	7,410	5,470	6,220	6,340	7,080
38	180~200	8,100	9,000	9,090	10,000	7,570	8,470	8,550	9,470	6,850	7,730	7,810	8,720	6,430	7,340	7,420	8,340
	220~260	8,520	9,470	9,470	10,390	7,980	8,930	8,930	9,850	7,260	8,190	8,190	9,100	6,850	7,800	7,800	8,720
45	180~200	10,180	11,100	11,190	12,100	9,470	10,390	10,480	11,380	8,750	9,650	9,770	10,710	8,110	9,030	9,120	10,020
	220~260	10,720	11,640	11,640	12,550	10,000	10,920	10,920	11,840	9,330	10,170	10,250	11,170	8,640	9,560	9,560	10,480
50	200~220	12,770	13,970	13,840	15,070	11,950	13,140	13,020	14,250	10,950	12,180	12,060	13,290	10,250	11,440	11,320	12,550
	240~260	13,380	14,600	14,450	15,750	12,560	13,790	13,630	14,930	11,630	12,850	12,700	13,920	10,860	12,090	11,930	13,230
60	200~220	15,550	17,030	16,950	18,430	14,550	16,030	15,950	17,430	13,310	14,800	14,710	16,190	12,490	13,970	13,890	15,370
	240~260	16,290	17,750	17,520	19,050	15,300	16,750	16,520	18,050	14,080	15,530	15,300	16,750	13,230	14,690	14,460	15,990

Type	材質	硬度	表面処理
MSP	SUJ2	S45C	取付キャップ
BSPM	S45C		
BSPK	S45C		
STM	S45C		四三酸化鉄皮膜 (Fe3O4)
STK	S45C		四三酸化鉄皮膜 (Fe3O4) 付属品 CB

Type	材質	硬度
MBB	SUJ2	
LBB	S45C	
MBSH	S45C	
MBS	S45C	
MBS	A5056	(アルミニウム)

Type	材質
MBJH	POM
MBJ	POM
SWP	SWP-B

ダイセット用  
ガイドポスト用