

ベアリングホルダセット -T型押し加工品-

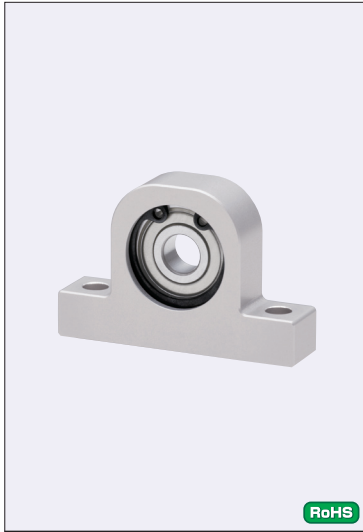

Type	材質		S表面処理	A付属品
	ベアリング	ホルダ	ホルダ	止め輪
C-BGHKA	スチール	アルミ合金	白アルマイト処理	ばね用鋼

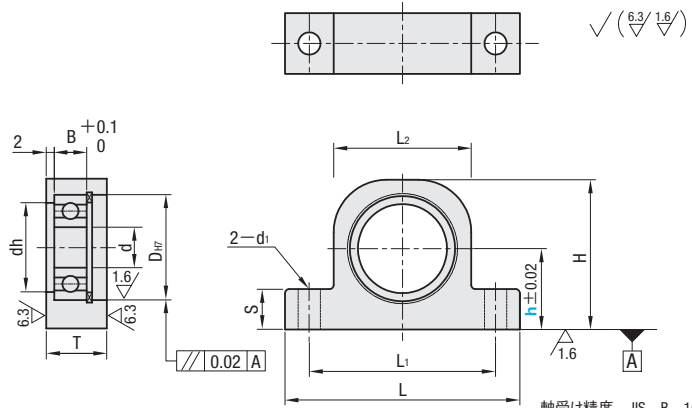

Type	ベアリング品番	h選択	d	H	L1	d1	L	L2	T	S	dh	DH7	B	使用ベアリング			¥基準単価
														基本定格荷重		許容回転数 rpm(参考)	
														Cr(動) kN	Cor(静) kN		
C-BGHKA	608ZZ	20	8	35	41	5.5	53	29	12	10	18	22	7	3.35	1.4	32000	1,630
		25	40	5.5	53	29	10	10	10								
		30	45	5.5	53	29	15	15	15								
	6900ZZ	20	10	45	41	5.5	53	29	12	10	19	22	6	2.7	1.27	30000	1,880
		30	45	5.5	53	29	15	15	10								
		40	55	5.5	53	29	10	10	10								
	6901ZZ	20	12	47	46	5.5	58	34	12	10	21	24	6	2.89	1.46	27000	1,890
		30	47	5.5	58	34	15	15	10								
		40	57	5.5	58	34	10	10	10								
	6000ZZ	20	10	47	46	5.5	58	34	15	10	22	26	8	4.55	1.96	29000	1,690
		30	47	5.5	58	34	15	15	10								
		40	57	5.5	58	34	10	10	10								
	6001ZZ	20	12	50	54	6.5	68	40	15	10	24	28	8	5.1	2.39	26000	1,790
		30	50	6.5	68	40	15	15	15								
		40	60	6.5	68	40	15	15	15								
	6902ZZ	20	15	60	54	6.5	68	40	12	15	25	28	7	3.65	2	24000	1,890
		30	60	6.5	68	40	15	15	10								
		40	70	6.5	68	40	15	15	10								
	6200ZZ	20	10	50	54	6.5	68	40	15	10	24	30	9	5.1	2.39	25000	1,710
		30	50	6.5	68	40	15	15	10								
		40	60	6.5	68	40	15	15	10								
	6201ZZ	20	12	50	54	6.5	68	40	16	10	26	32	10	6.1	2.75	22000	1,800
		30	50	6.5	68	40	15	15	10								
		40	60	6.5	68	40	15	15	10								
6002ZZ	20	15	60	54	6.5	68	40	15	15	28	32	9	5.6	2.83	22000	1,880	
	30	60	6.5	68	40	15	15	10									
	40	70	6.5	68	40	15	15	10									



Delivery
出荷日



在庫品

翌日出荷

◎ご希望によりPM5:00迄、当日出荷受付致します。



Example
使用例

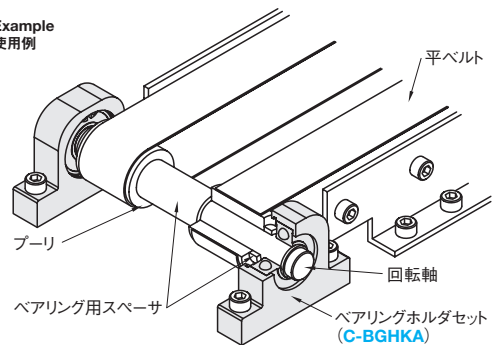

■数量スライド価格 (◎1円未満切り捨て)

数量	1~9	10~14	15~19	20~49	50~100
値引率		5%	10%	18%	30%

◎表示数量超えはお見積り