

EMVL-MP2514

FIXED FOCAL (MACHINE VISION) 2/3" 25 mm 1.4 C

SPECIFICATIONS

1 Focal Length	-----	25.0 mm
2 Relative Aperture	-----	1.4
3 Image Format	-----	2/3" ϕ 11 (8.8 X 6.6mm)
4 Angular Field of View	-----	24.95° (20.1° × 15.1°)
5 M.O.D.	-----	0.25m
6 Object Area at M.O.D.	-----	72.1 X 54.1mm
7 Back Focal Length	-----	13.13 mm
8 Exit Pupil	-----	-32.67mm
9 Mount Type	-----	"C" MOUNT
10 Iris System	-----	MANUAL 1.4 ~ 16
11 TV Distortion	-----	-0.3%
12 Vignetting	-----	-38%
13 Weight	-----	45g

DIMENSIONS

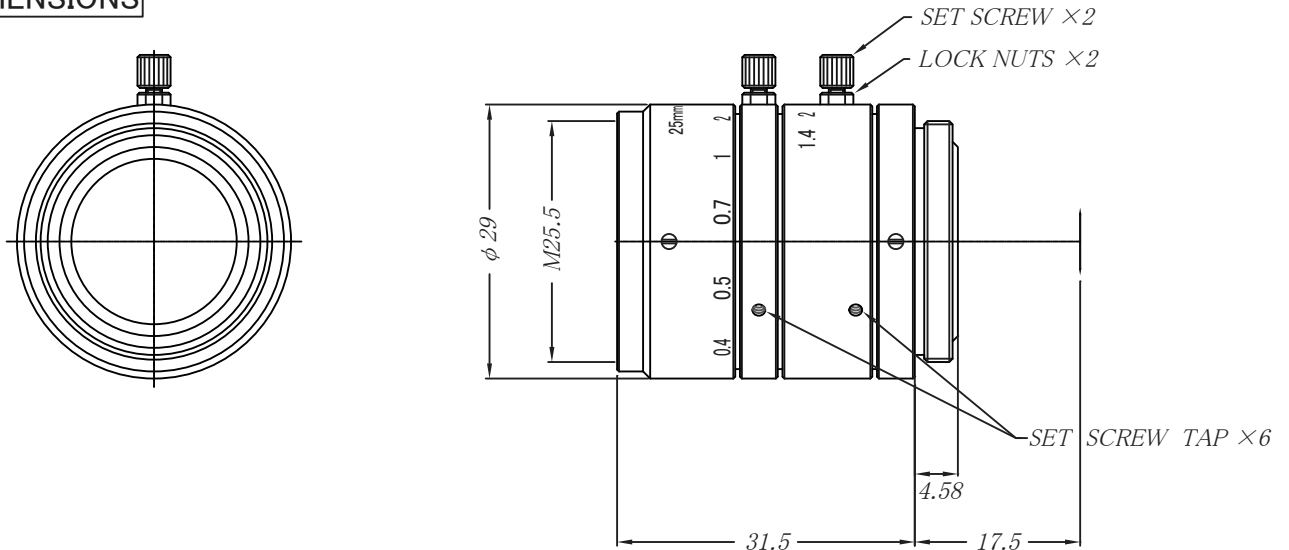

MAGNIFICATION

() : 14" MONITOR TV

O/I = 2000mm : -0.01281X (0.41X)	O/I = 400mm : -0.07028X (2.27X)
O/I = 1000mm : -0.02619X (0.84X)	O/I = 300mm : -0.09788X (3.16X)
O/I = 700mm : -0.03814X (1.23X)	O/I = 250mm : -0.12195X (3.94X)
O/I = 500mm : -0.05485X (1.77X)	